

Dual Polarized Horn Antenna

WR-4.3/200-240GHz/26dBi Min, Gain

Model:TL-4DPHA25-T1

TL-4DPHA25-T1 is a dual polarized horn antenna that operates from 200 to 240GHz, The antenna offers 26dBi minimum gain. The antenna VSWR is 1.2:1 typical. The antenna cross polarization isolation is typical 55 dB. The antenna RF port is WR-4.3 waveguides and UG-387/U-M anti-cocking flanges. It can be widely used in EMI detection, orientation, reconnaissance, antenna gain and pattern measurement and other application fields.

Features:

- Operating Frequency 200 to 240GHz
- Gain: 26dBi Min
- Dual Linear Polarization

Applications:

- Radar Systems
- Communication Systems

Electrical Characteristics:



Parameter	Min	Typ	Max	Units
Frequency Range	200		240	GHz
Gain	26			dBi
Polarization mode	Dual Linear			
Input VSWR		1.2		:1
3dB Antenna Beamwidth		E: 6.7; H: 6.87		°
Port to Port Isolation		55		dB
Cross Polarization Isolation		45		dB

Physical Characteristics:

Description	Parameter	Units
Material	Copper	
Finish	Gold plated	
Waveguide Connectors	WR-4.3/UG-387/U	
Size	81.12*22.08*19.09	mm
Weight	0.129	Kg

Outline Drawing:

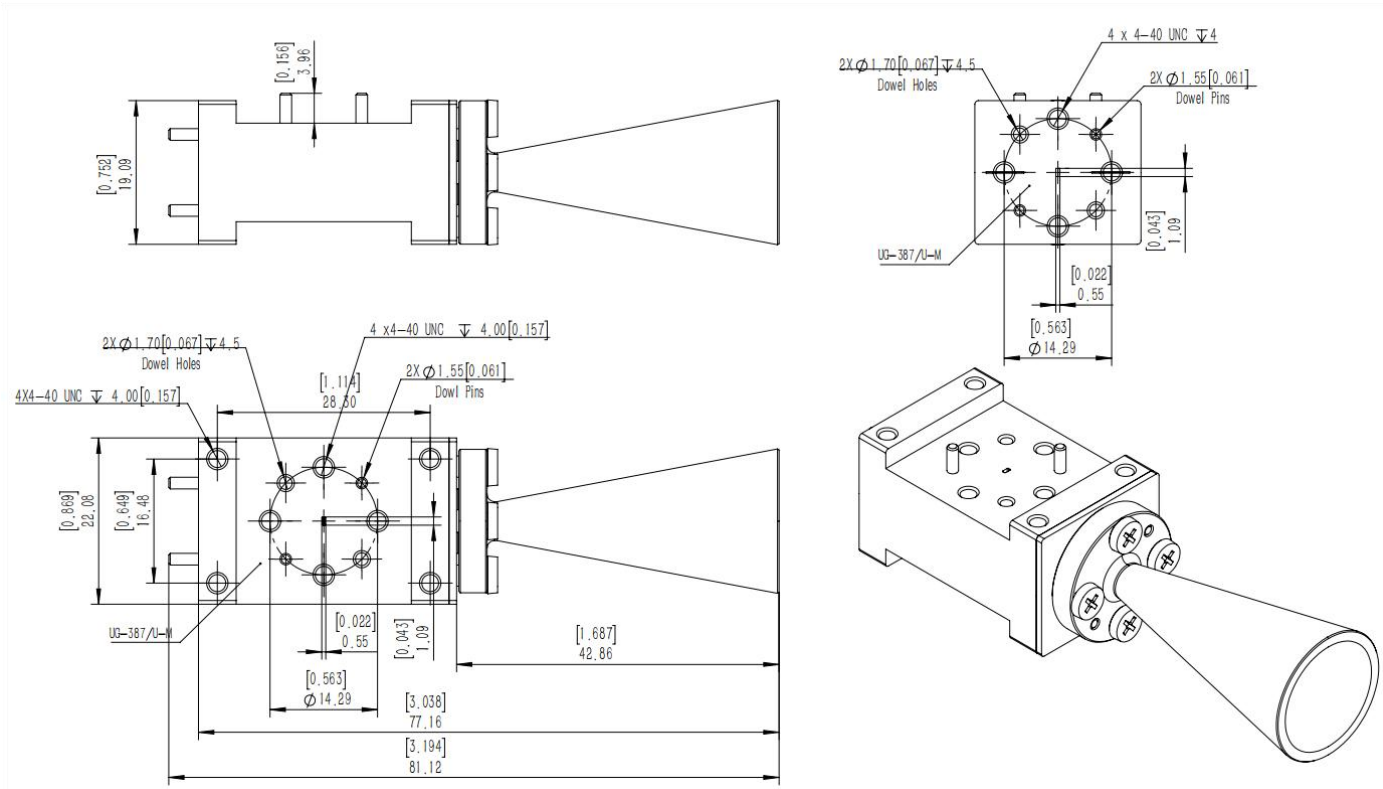
Unit:mm

ESD Protection: Strictly adhere to ESD precautions to prevent electrostatic damage.

Ordering Information:

Base Number	Description	Revision
TL-4DPHA25-T1	Dual Polarized Horn Antenna, 200-240GHz, Gain: 26dBi Min, WR-4.3	Rev.1.1

Typical Performance Data:

VSWR vs Frequency

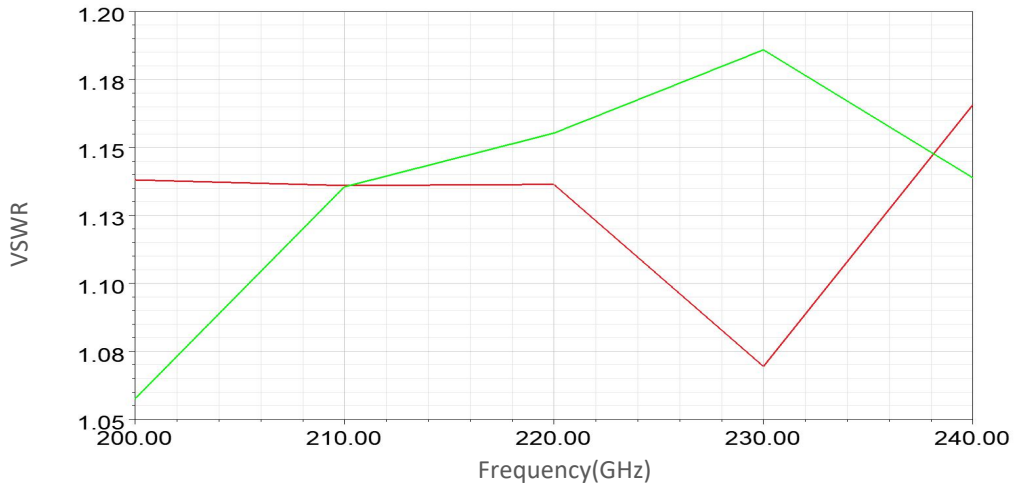

Gain vs Frequency

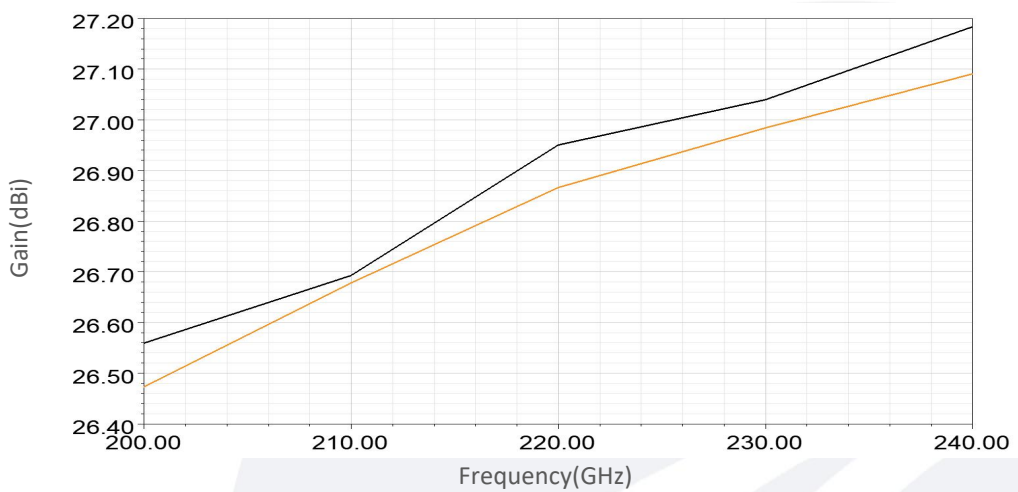

Port Isolation vs Frequency

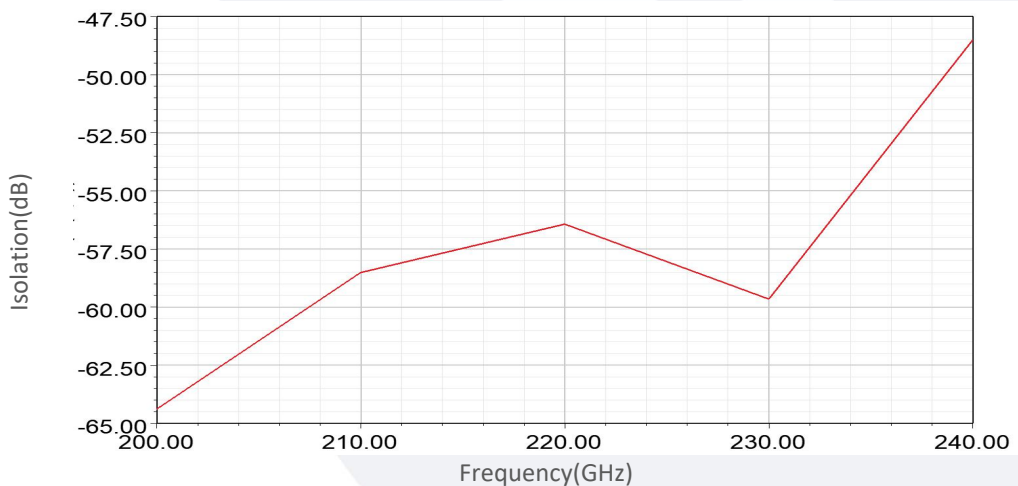

Note: Above data is for ref only, actual data may vary from unit to unit depending on operating environment and other factors like material lots etc.

Typical Performance Data:

Cross Polarization vs Frequency

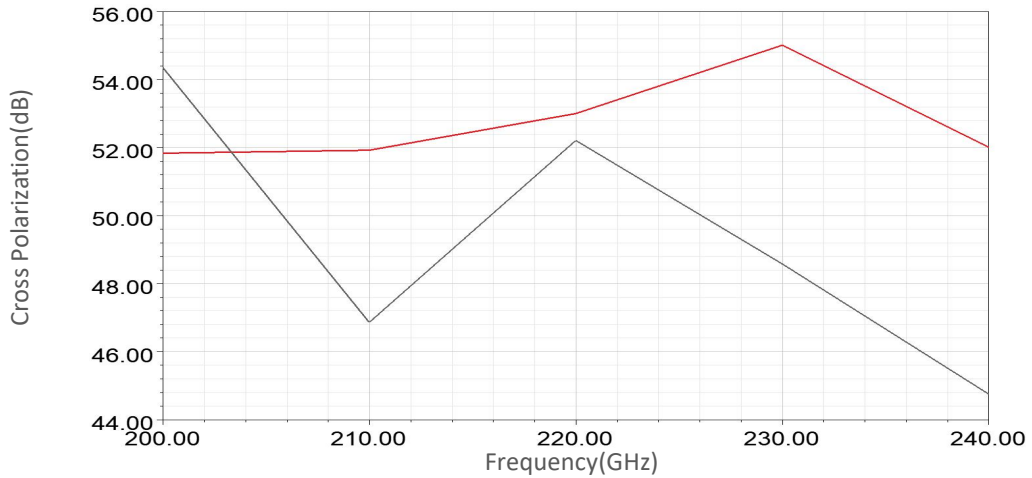

E-Plane:

Amplitude vs Theta

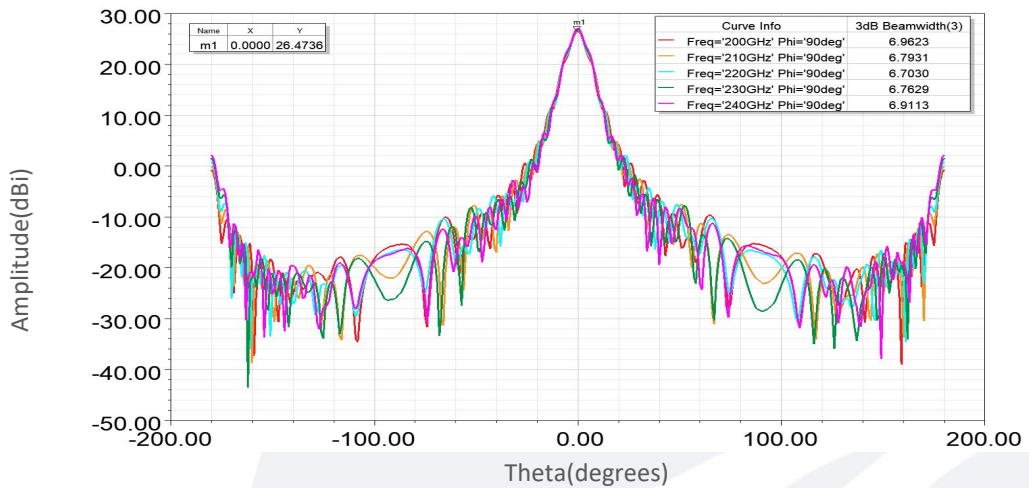

H-Plane:

Amplitude vs Theta

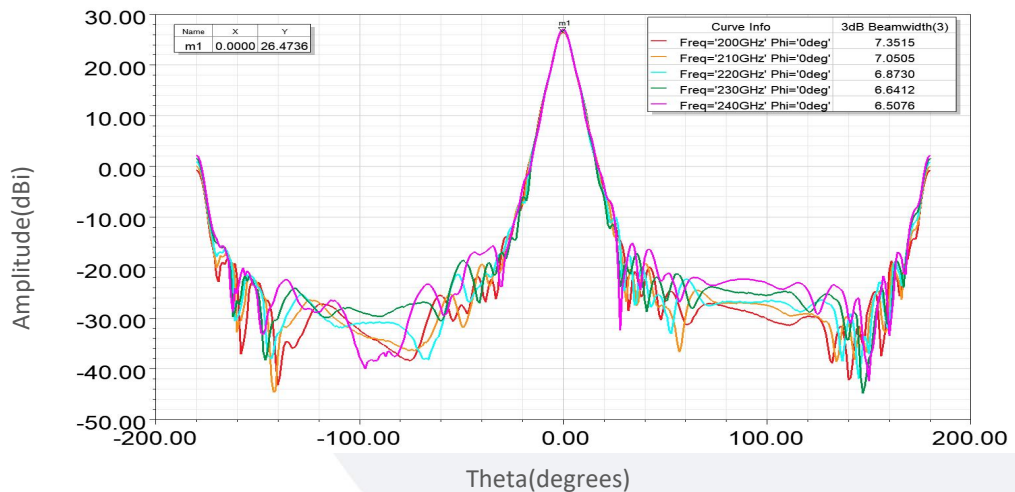

Note: Above data is for ref only, actual data may vary from unit to unit depending on operating environment and other factors like material lots etc.