

Waveguide to Coax Adapter, End Launch WR-10/1.0mm Male/75-110GHz

Model: TL-10WCA1.0ME-CU

The TL-10WCA1.0ME-CU is end launch waveguide to coax adapters that cover the frequency range of 75 to 110 GHz. It is designed for an efficient transition between the rectangular waveguide and 1.0 mm coax connector.

Features:

- Operating Frequency 75 to 110GHz
- Lower Insertion Loss and VSWR
- Instrumentation Grade
- DC Short Circuit

Applications:

- Test Lab
- Instrumentations
- Sub-assemblies

Electrical Characteristics:



Parameter	Min	Typ	Max	Units
Frequency Range	75		110	GHz
VSWR		1.3		:1
Insertion Loss		0.6		dB
Power Handling			2	W

Environmental And Physical Characteristics:

Description	Parameter	Units
Operating Temperature	-40 To +85	°C
Storage Temperature	-40 to +85	°C
Material	Copper	
Finish	Gold Plated	
Coax Connector	1.0mm Male	
Waveguide	WR-10/UG-387/U-M	

Outline Drawing:

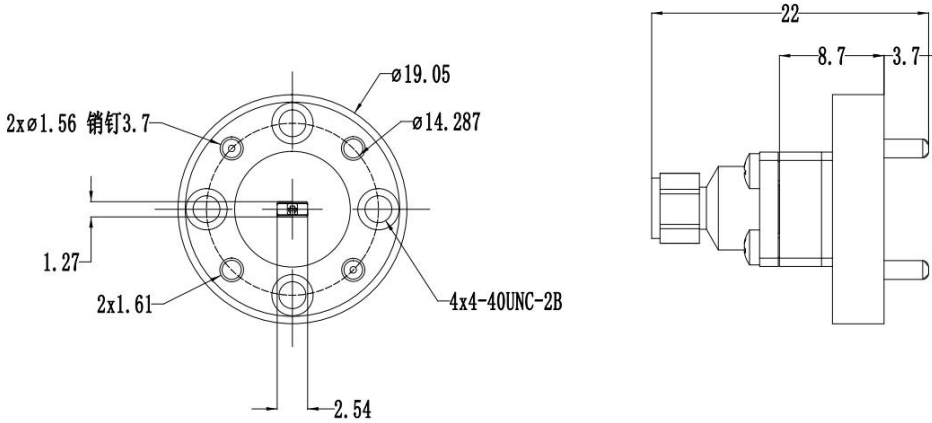
Unit:mm

ESD Protection: Strictly adhere to ESD precautions to prevent electrostatic damage.

Ordering Information:

Base Number	Description	Revision
TL-10WCA1.0ME-CU	Waveguide to Coax Adapter, End Launch WR-10/1.0mm Male,75-110GHz	Rev.1.1

Typical Performance Data:

VSWR vs Frequency

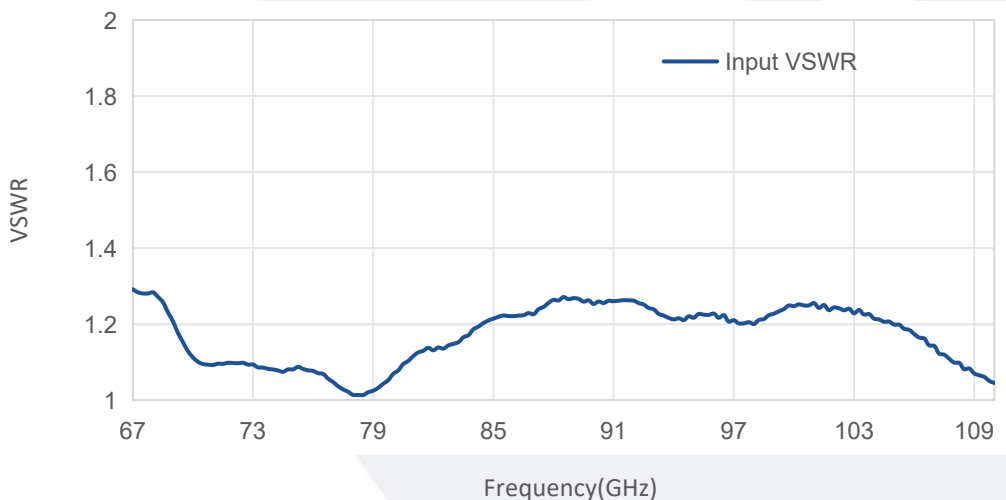

Note: Above data is for ref only, actual data may vary from unit to unit depending on operating environment and other factors like material lots etc.

Typical Performance Data:

Insertion Loss vs Frequency

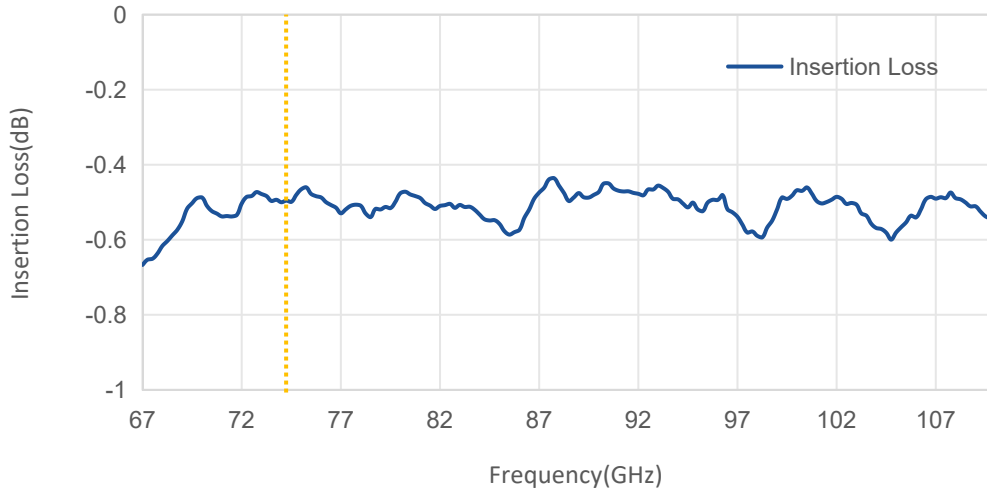

Note: Above data is for ref only, actual data may vary from unit to unit depending on operating environment and other factors like material lots etc.