

Standard Gain Horn Antenna

WR-10/75-110GHz/20dBi Typ, Gain

Model:TL-10SHA20

TL-10SHA20 is a standard gain horn antenna that operates from 75 GHz to 110 GHz. The antenna offers 20dBi nominal gain. The input of this antenna is a WR-10 waveguide with UG-387/U-M anti-cocking flange. The standard gain horn is offered for antenna range calibration purpose mainly, but it can be also used for general purpose system set ups.

Features:

- Operating Frequency 75 to 110 GHz
- Gain: 20dBi Typ
- Good Impedance Match

Applications:

- Antenna Ranges
- Antenna Gain Measurements
- System Setups

Electrical Characteristics:

Parameter	Min	Typ	Max	Units
Frequency Range	75		110	GHz
Gain		20		dBi
Input VSWR			1.3	:1

Environmental And Physical Characteristics:

Description	Parameter	Units
Material	Copper	
Finish	Gold plated	
Connectors	WR-10/UG-387/U	
Length	29.6	mm

Outline Drawing:

Unit:mm

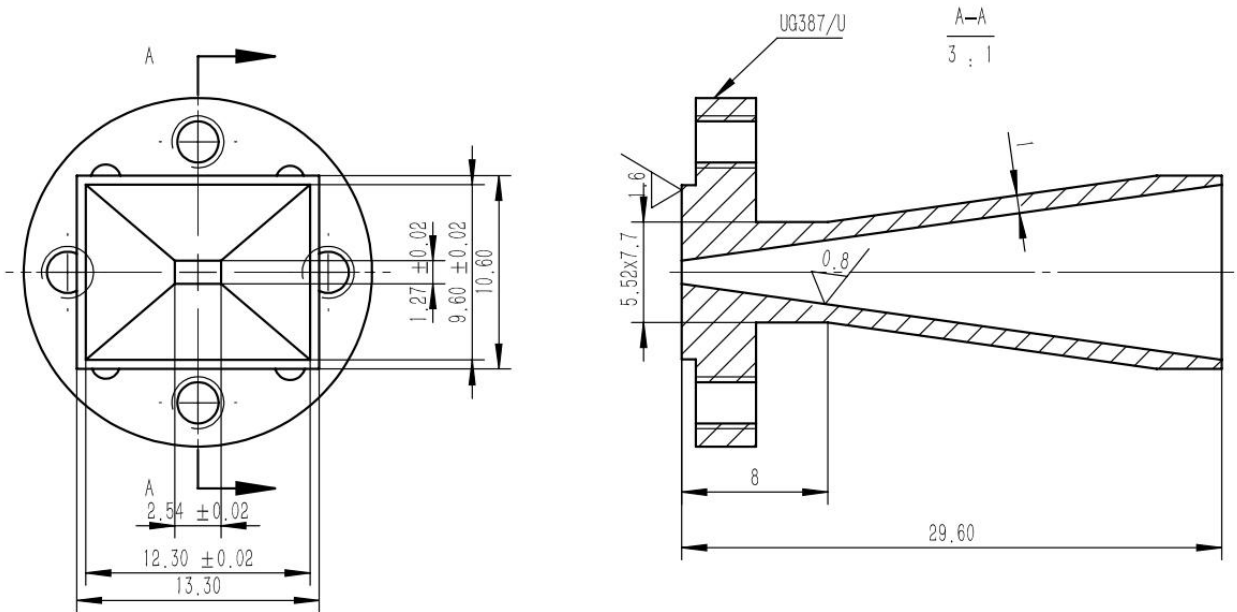

ESD Protection: Strictly adhere to ESD precautions to prevent electrostatic damage.

Ordering Information:

Base Number	Description	Revision
TL-10SHA20	Standard Gain Horn Antenna, 75-110GHz, Gain: 20dBi Typ.	Rev.1.0

Typical Performance Data:

Gain vs Frequency

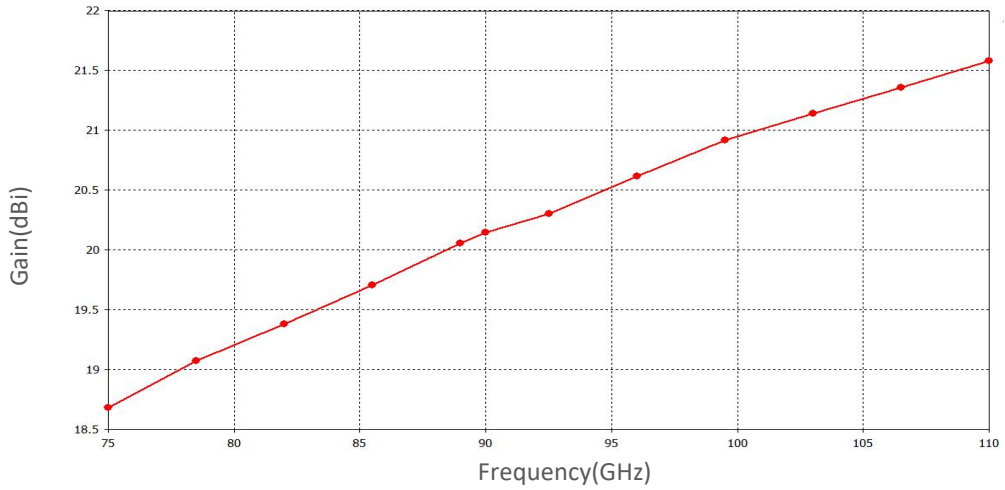

E:75GHz:

Amplitude vs Theta



H:75GHz:

Amplitude vs Theta

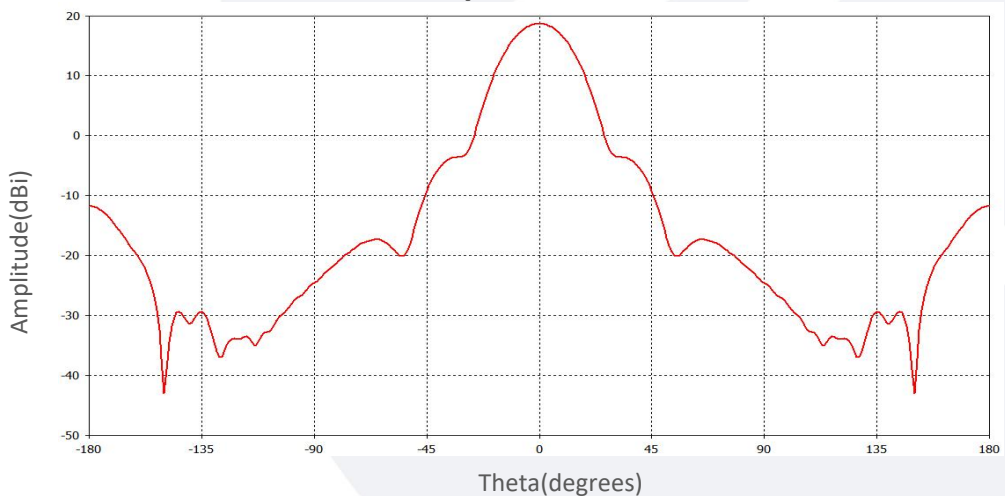

Note: Above data is for ref only, actual data may vary from unit to unit depending on operating environment and other factors like material lots etc.

Typical Performance Data:

E:85.5GHz:

Amplitude vs Theta

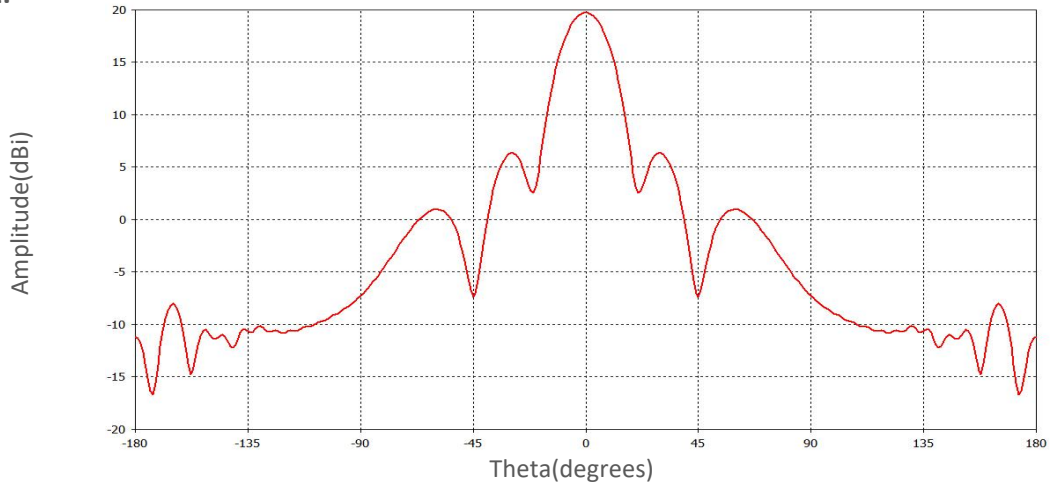

H:85.5GHz:

Amplitude vs Theta

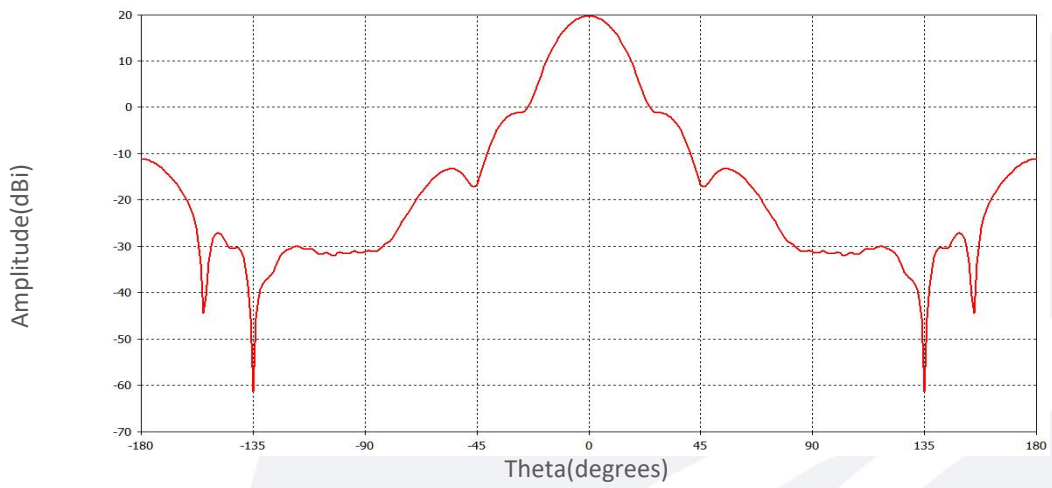

E:92.5GHz:

Amplitude vs Theta



Note: Above data is for ref only, actual data may vary from unit to unit depending on operating environment and other factors like material lots etc.

Typical Performance Data:

H:92.5GHz:

Amplitude vs Theta

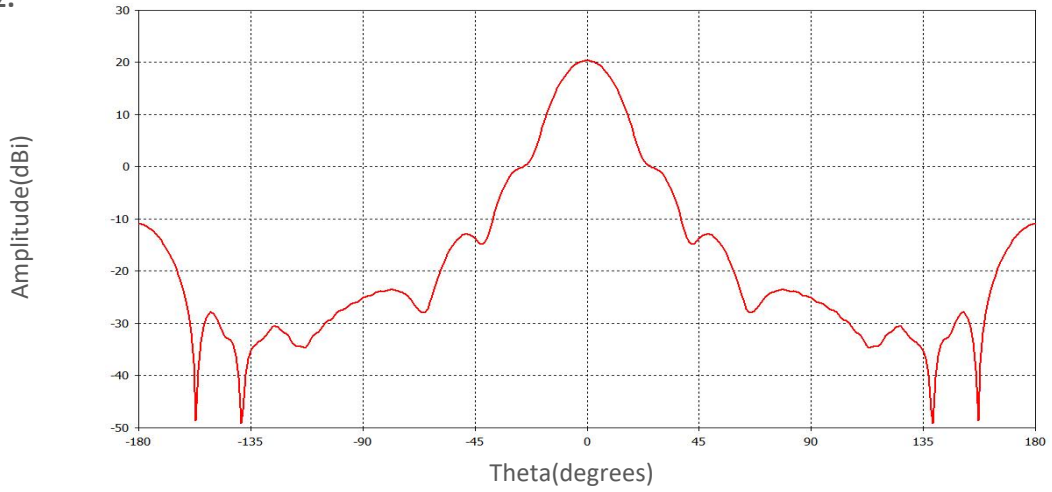

E:99.5GHz:

Amplitude vs Theta

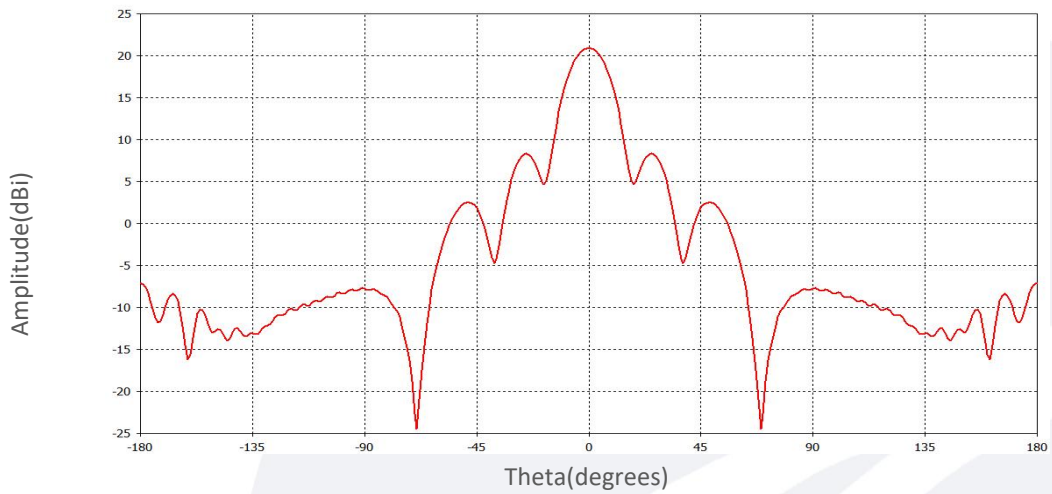

H:99.5GHz:

Amplitude vs Theta



Note: Above data is for ref only, actual data may vary from unit to unit depending on operating environment and other factors like material lots etc.

Typical Performance Data:

E:110GHz:

Amplitude vs Theta

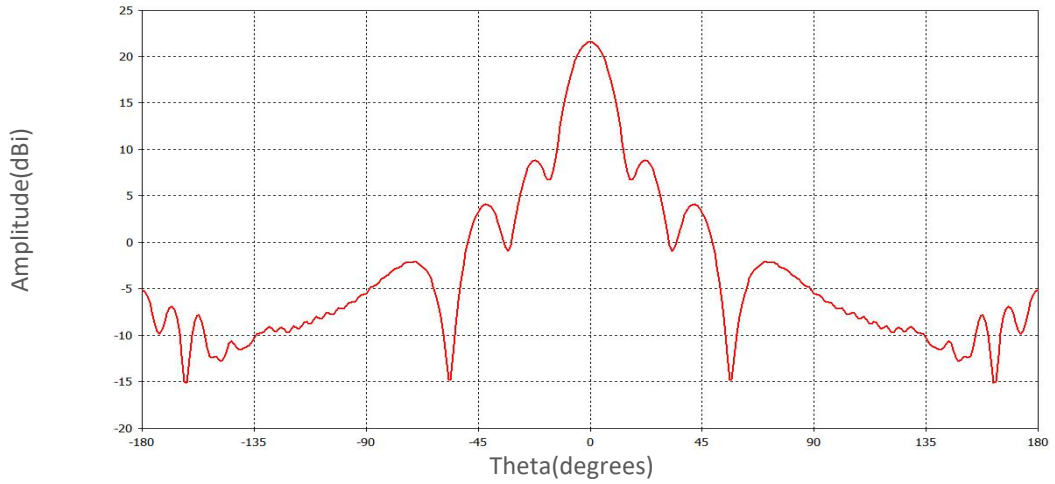

H:110GHz:

Amplitude vs Theta

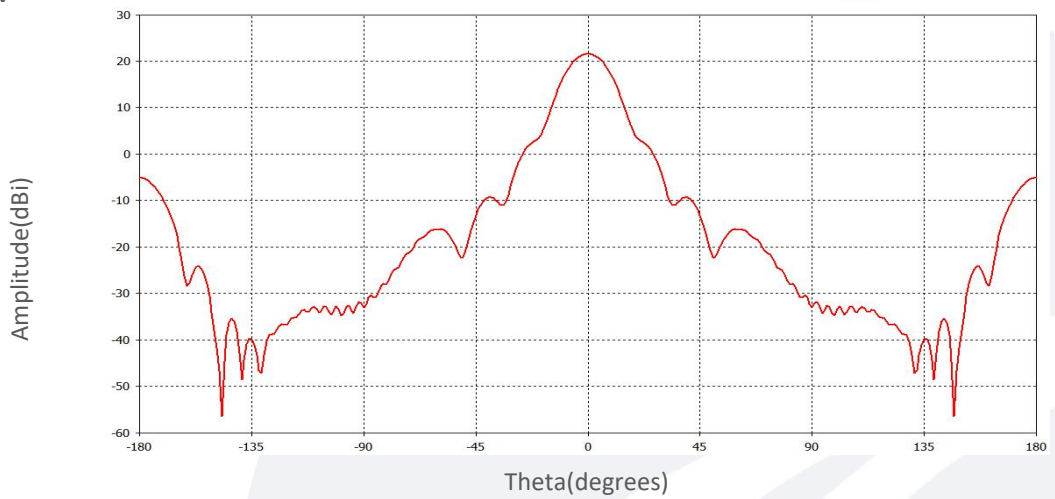

Note: Above data is for ref only, actual data may vary from unit to unit depending on operating environment and other factors like material lots etc.