

## Power Amplifier

6-18GHz/37dB Gain/37dBm Psat

Model: TLPA6G18G-37-37

TLPA6G18G-37-37 is a power amplifier with a minimum small signal gain of 37 dB and a minimum Psat of 37 dBm across the frequency range of 6 to 18 GHz. The DC power requirement for the amplifier is +28 VDC/2.5 A. The input and output port configuration offers coax adapter structure with SMA female.

### Features:

- Frequency range: 6-18GHz
- Gain: 37dB Min
- Output Power Psat: 37dBm Min
- Good Power and Gain Flatness
- 50 Ohm Matched Input / Output

### Applications:

- Cellular
- PCN
- GSM
- ISM
- Lab Test

### 电气特性 Electrical Characteristics:

参数 Parameter	Min	Typ	Max	单位 Units
频率范围 Frequency range	6		18	GHz
小信号增益 Small Signal Gain	37			dB
饱和输出功率 Output Psat	37			dBm
杂散 Spurious			-50	dBc
谐波抑制 Harmonic			-10	dBc
输入驻波 Input VSWR		2		:1
直流电压 DC Voltage		+28		V DC
直流电流 DC Supply Current		2	2.5	A
阻抗 Impedance		50		Ohms

### 机械特性 Mechanical Specifications:

参数 Parameter	指标 Value	单位 Units
输入/输出接口 Input /Output Connector	SMA Female/SMA Female	
直流偏置 DC Bias	Feedthru capacitors	

### 机械特性 Mechanical Specifications:

参数 Parameter	指标 Value	单位 Units
尺寸 Size	60*60*11(Without heatsink) 188*125*146(With heatsink)	mm
重量 Weight	≤200	g

### 绝对最大值 Absolute Maximum Ratings:

参数 Parameter	指标 Value
供电偏置电压 Supply Bias Voltage	+29 V
输入功率 RF Input Power	+5 dBm
ESD灵敏度 ESD sensitivity (HBm)	Class 0, passed 150V



### 外形图 Outline Drawing:

Unit:mm

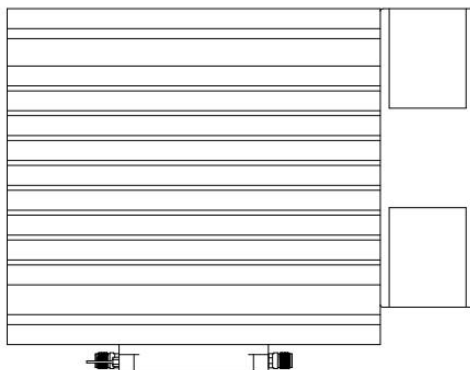
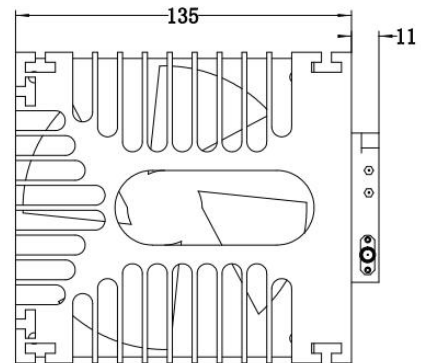
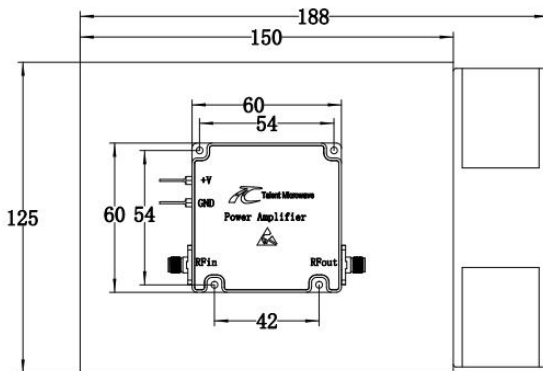

ESD Protection: Strictly adhere to ESD precautions to prevent electrostatic damage.

## 温度环境 Environmental Conditions:

参数 Parameter	Min	Typ	Max	单位 Units
操作温度 Operating Temperature*	-40		+60	°C
存储温度 Non-operating Temperature*	-50		+70	°C
相对湿度 Relative humidity		95		%
海拔 Altitude	10,000			feet
震动 Shock / Vibration(MIL-STD-810F)	25g rms (15 degree 2KHz) endurance, 1 hour per axis			
冲击 Shock(non operating)	20G for 11msc half sin wave,3 axis both directions			

\*Note: For a wider temperature range, please consult the manufacturer.

## 订货信息 Ordering Information:

标准型号 Base Number	描述 Description	版本号 Revision
TLPA6G18G-37-37	Power amplifier 6-18GHz, Gain:37dB,Psat:37dBm,+28V DC,With Heatsink	Rev.1.1

## 典型曲线 Typical Performance Data:

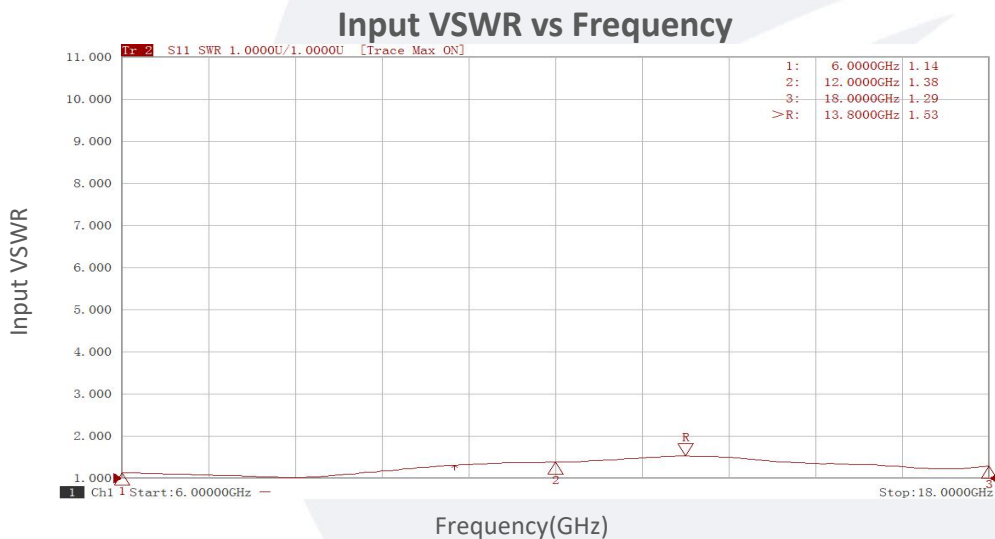

Note: Above data is for ref only, actual data may vary from unit to unit depending on operating environment and other factors like material lots etc.

## 典型曲线 Typical Performance Data:

### Small Signal Gain vs Frequency

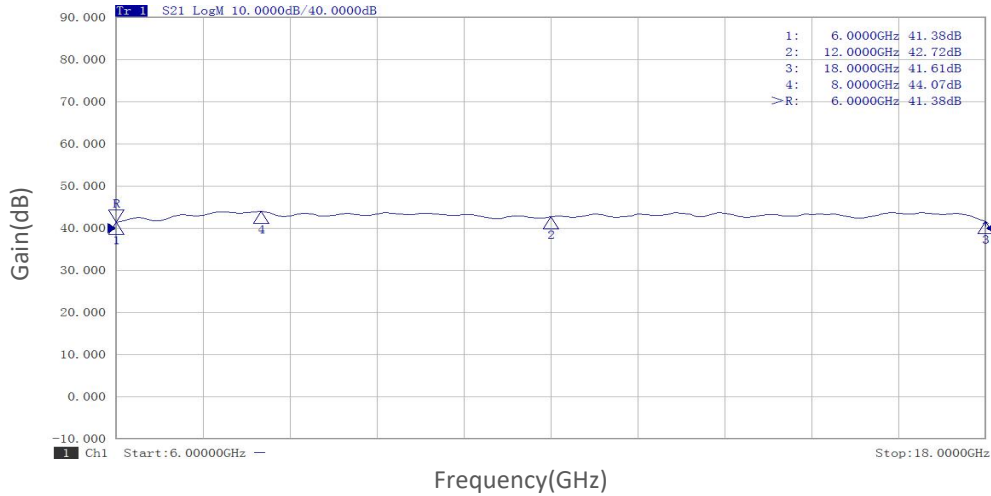

### PndB vs Frequency

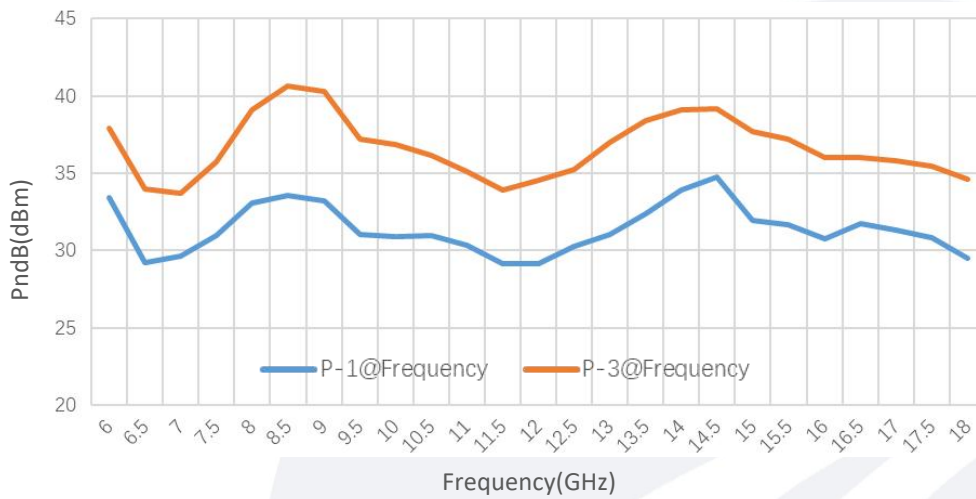

### Pout@Pin

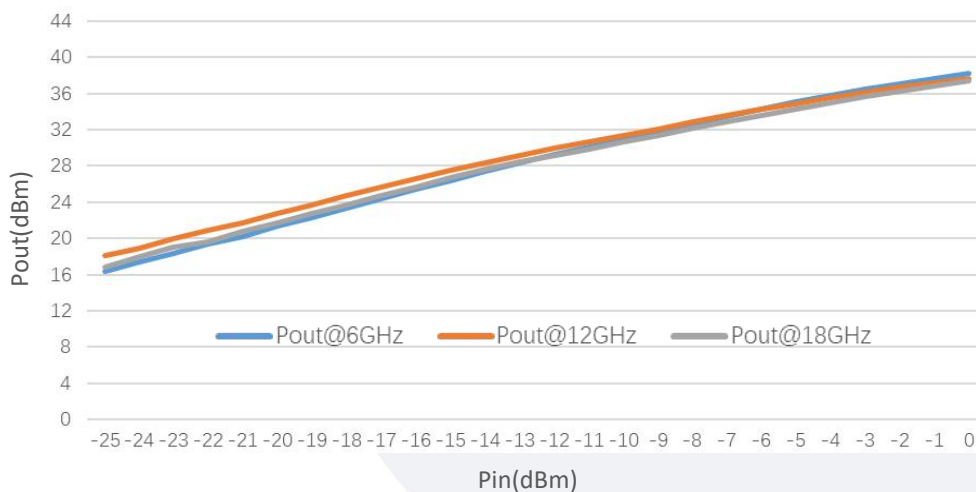

Note: Above data is for ref only, actual data may vary from unit to unit depending on operating environment and other factors like material lots etc.

## 典型曲线 Typical Performance Data:

### Pout@Equal\_Pin

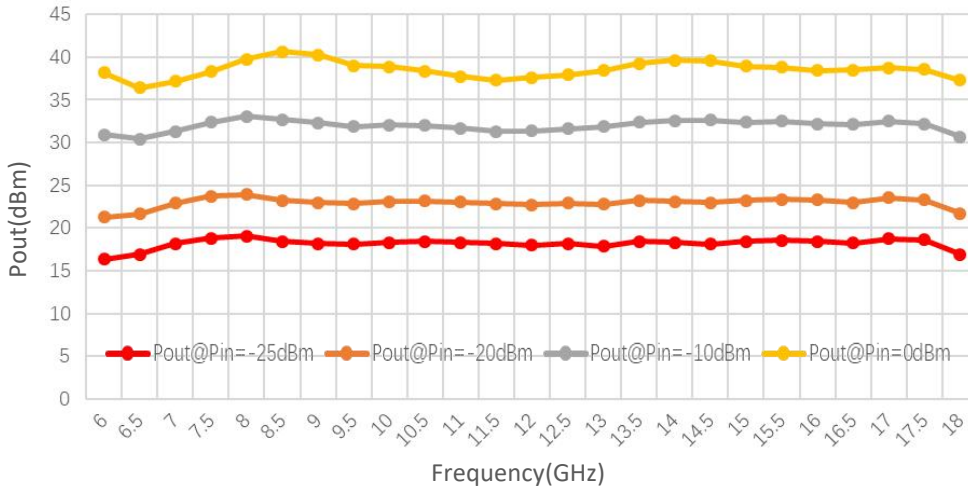

### Spurious vs Frequency

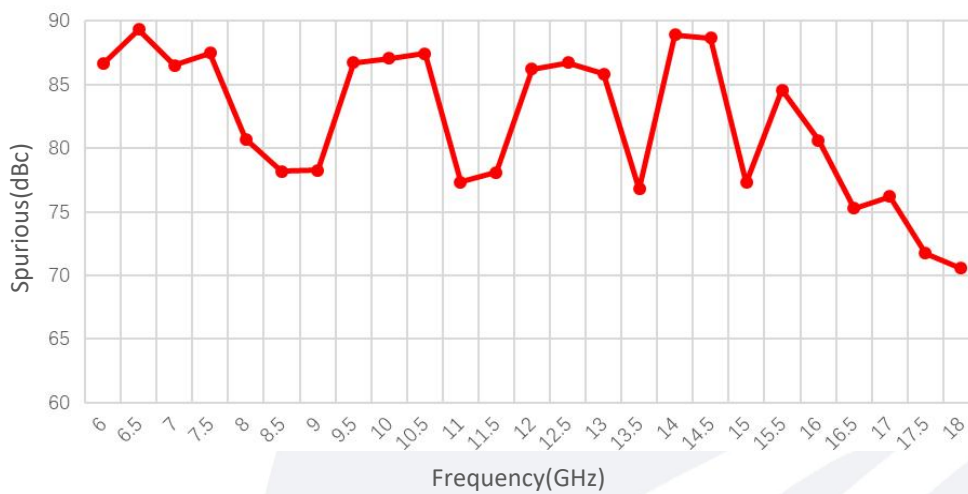

### Harmonic vs Frequency

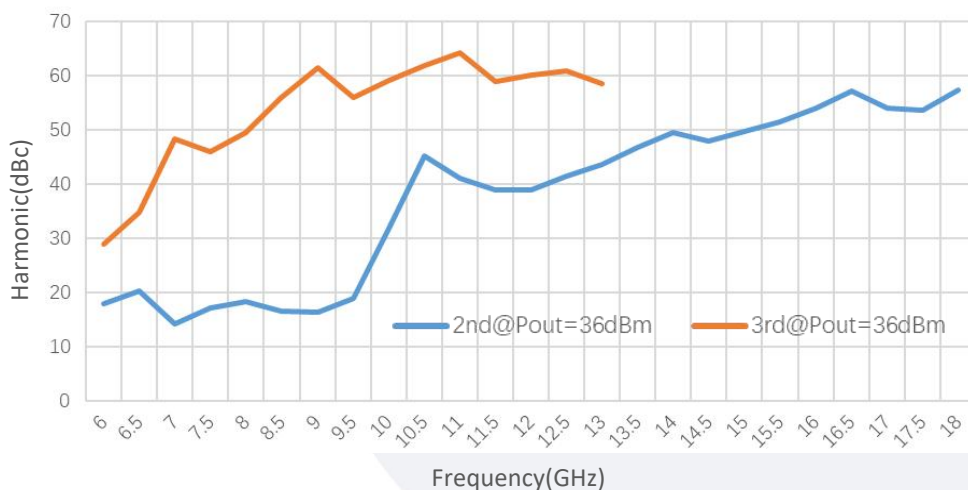

Note: Above data is for ref only, actual data may vary from unit to unit depending on operating environment and other factors like material lots etc.