

## 6-Bit Digital Phase Shifter

Step 5.625°/0-360°/ 0.3-3GHz

Model: TLDP0.3G3G-360-6

The TLDP0.3G3G-360-6 is a 6-bit digital phase shifter, Step size is 5.6° providing phase shift from 0° to 360° in 5.6° steps. This design has been optimized to minimize variation in attenuation over the phase shift range. The TLDP0.3G3G-360-6 is ideally suited for use where high phase accuracy with minimum loss variation over the phase shift range are required. Typical applications include communications antennas and phased array radars.

### Features:

- Frequency range: 0.3-3GHz
- High Phase Shift Accuracy
- High Phase Shift Range
- Low Phase Error

### Applications:

- Communications antennas
- Phased array radars

### 电气特性 Electrical Characteristics:

参数 Parameter	Min	Typ	Max	单位 Units
频率范围 Frequency range	0.3		3	GHz
插损 Insertion Loss		17		dB
输入驻波 Input VSWR		2		:1
输出驻波 Output VSWR		2		:1
移相范围 Phase Shift Range		360		°
相位精度 Phase accuracy		±3		°
耐功率 Power Handling			25	dBm
全相位范围内的插损波动 Insertion loss variation over phase range			±1	dB
切换时间 Switching speed		20		ns
直流电压 DC Voltage		+5		V DC
直流电流 DC Supply Current		20		mA
控制位数 Number of Bits		6		Bit
阻抗 Impedance		50		Ohms

## 环境和机械特性 Environmental And Physical Characteristics:

描述 Description	参数 Parameter	单位 Units
输入/输出接口 Input /Output Connector	SMA Female/SMA Female	
直流控制接口 DC and control interface	J30J-9ZKP	
尺寸 Size	28*20*15	mm

## 绝对最大值 Absolute Maximum Ratings :

描述 Description	参数 Parameter	单位 Units
供电偏置电压 Supply Bias Voltage	+5 (±5%)	V
射频输入功率 RF Input Power	25	dBm
ESD灵敏度 ESD sensitivity (HBm)	Class 0, passed 150V	

## 外形图 Outline Drawing:

Unit:mm

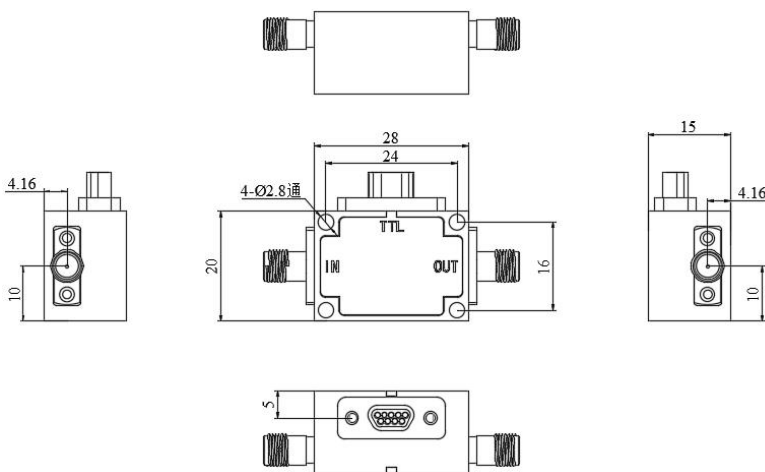

真值表 Truth Table

TTL Control Input						Signal Path
Bit1	Bit2	Bit3	Bit4	Bit5	Bit6	State
0	0	0	0	0	0	Reference
1	0	0	0	0	0	5.625
0	1	0	0	0	0	11.25
0	0	1	0	0	0	22.5
0	0	0	1	0	0	45
0	0	0	0	1	0	90
0	0	0	0	0	1	180
1	1	1	1	1	1	354.375

Note: +3.3V~+5V is "1"; 0V is "0"

PIN	1-6	7	8	9
Function	Bit1~Bit6	NC	+5V	GND



ESD Protection: Strictly adhere to ESD precautions to prevent electrostatic damage.

## 温度环境 Environmental Conditions:

参数 Parameter	Min	Typ	Max	单位 Units
操作温度 Operating Temperature	-45		+85	°C
存储温度 Non-operating Temperature	-55		+125	°C
相对湿度 Relative humidity		95		%
海拔 Altitude	10,000			feet
震动 Shock / Vibration(MIL-STD-810F)	25g rms (15 degree 2KHz) endurance, 1 hour per axis			
冲击 Shock(non operating)	20G for 11msc half sin wave,3 axis both directions			

## 订货信息 Ordering Information:

标准型号 Base Number	描述 Description	版本号 Revision
TLDP0.3G3G-360-6	6-Bit Digital Phase Shifter,0.3-3GHz,SMA	Rev.1.1

## 典型曲线 Typical Performance Data:

0° :

### VSWR&Insertion Loss&Phase vs Frequency

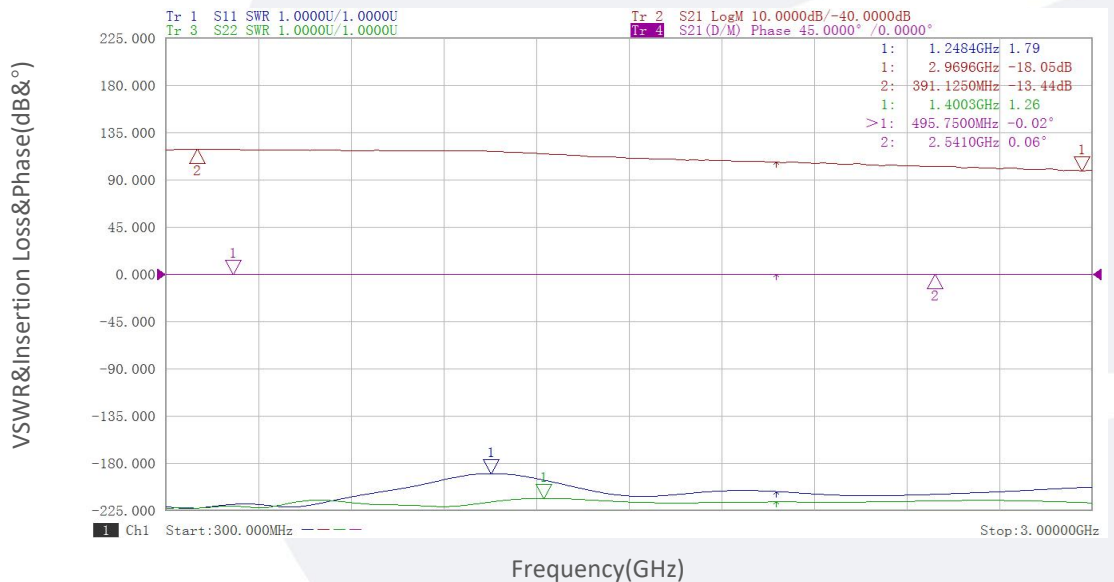

Note: Above data is for ref only, actual data may vary from unit to unit depending on operating environment and other factors like material lots etc.

典型曲线 Typical Performance Data:

5.625° :

VSWR&Insertion Loss&Phase vs Frequency

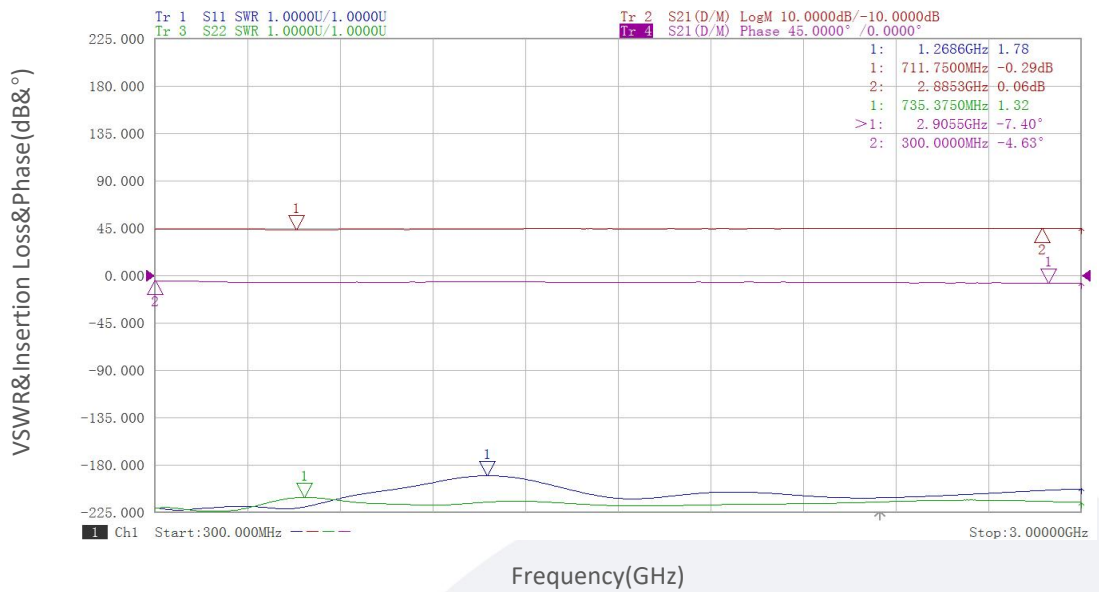

11.25° :

VSWR&Insertion Loss&Phase vs Frequency

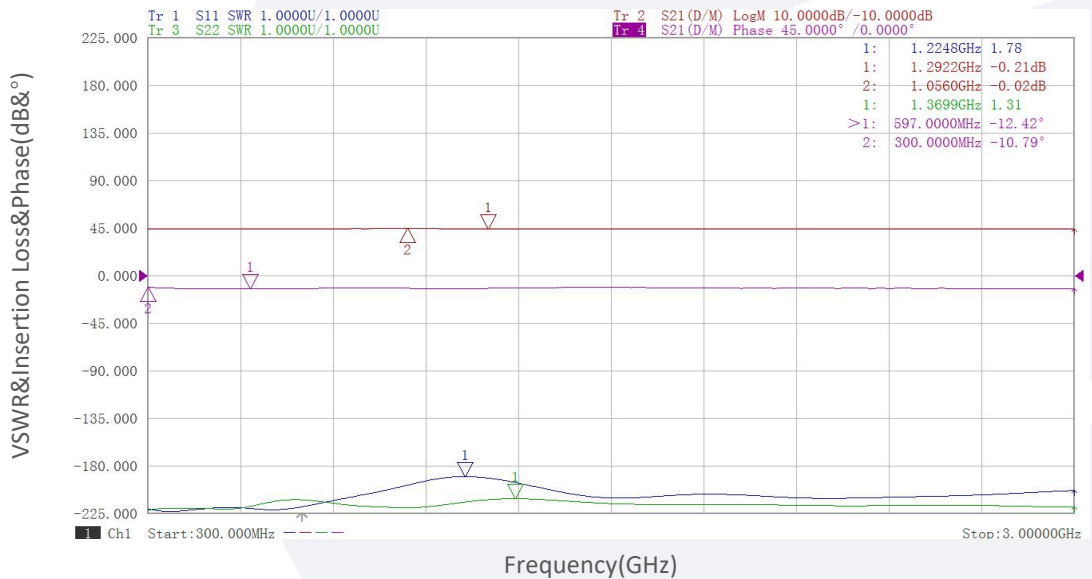

Note: Above data is for ref only, actual data may vary from unit to unit depending on operating environment and other factors like material lots etc.

典型曲线 Typical Performance Data:

22.5° :

VSWR&Insertion Loss&Phase vs Frequency

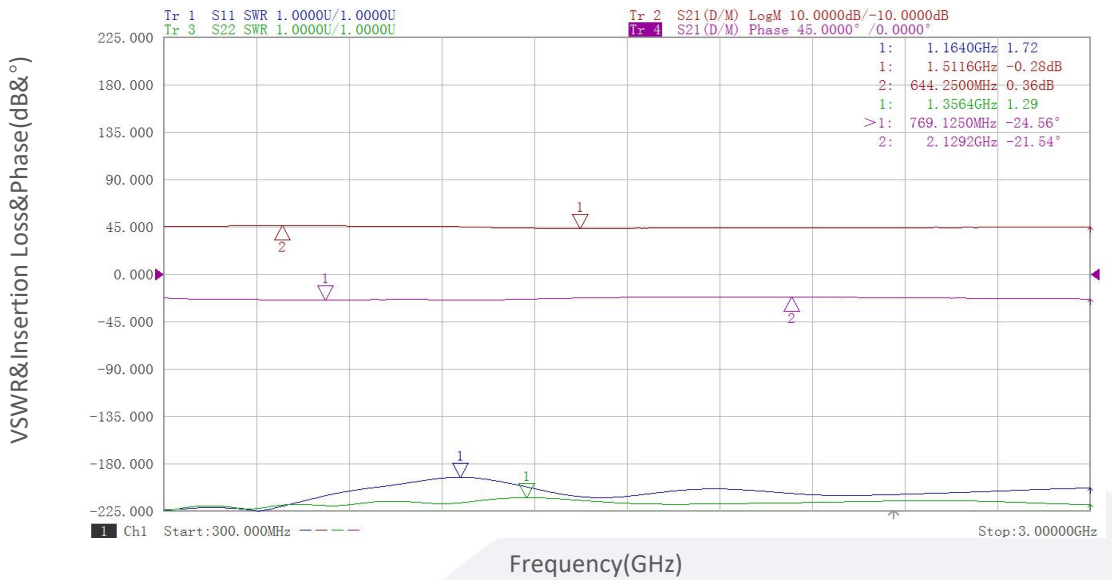

45° :

VSWR&Insertion Loss&Phase vs Frequency

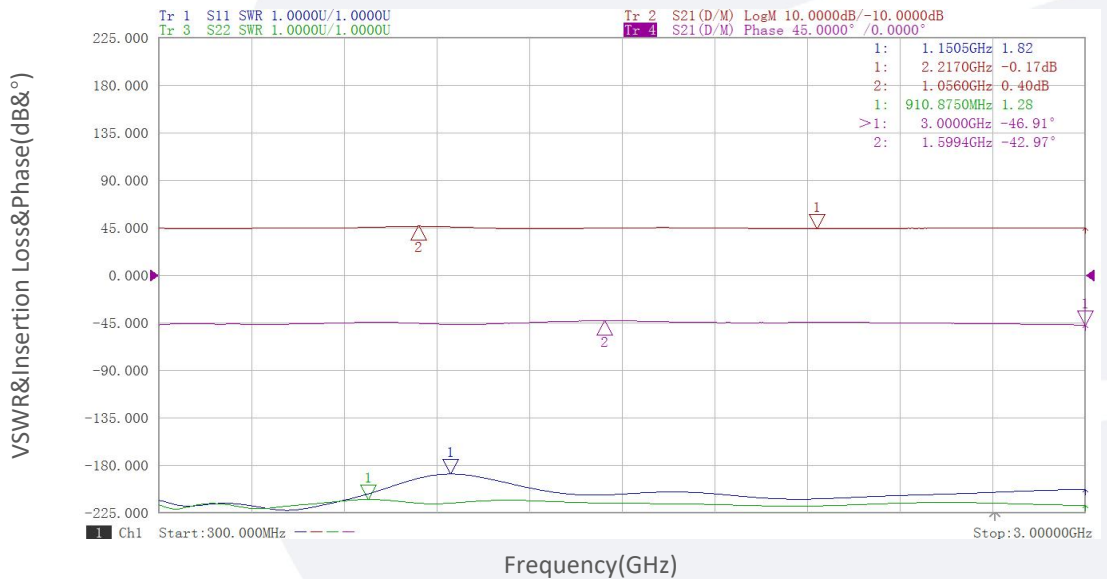

Note: Above data is for ref only, actual data may vary from unit to unit depending on operating environment and other factors like material lots etc.

典型曲线 Typical Performance Data:

90° :

VSWR&Insertion Loss&Phase vs Frequency

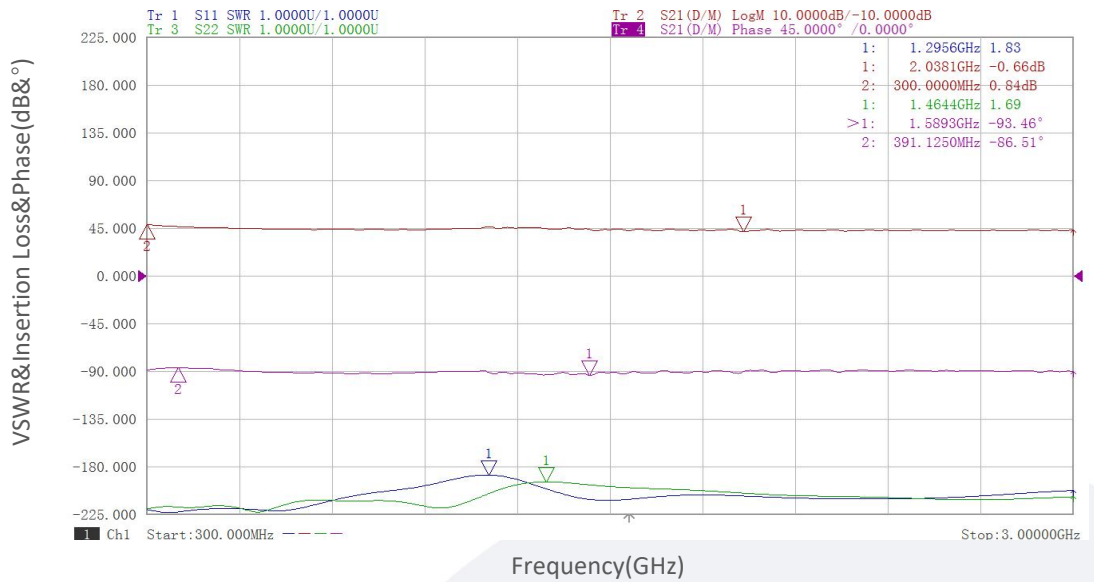

180° :

VSWR&Insertion Loss&Phase vs Frequency

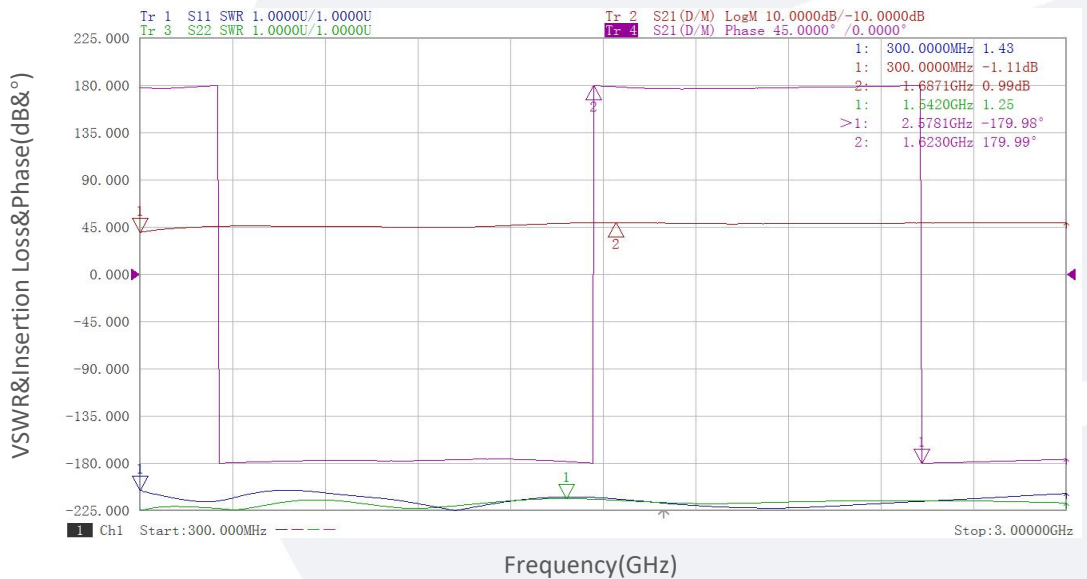

Note: Above data is for ref only, actual data may vary from unit to unit depending on operating environment and other factors like material lots etc.

典型曲线 Typical Performance Data:

360° :

VSWR&Insertion Loss&Phase vs Frequency

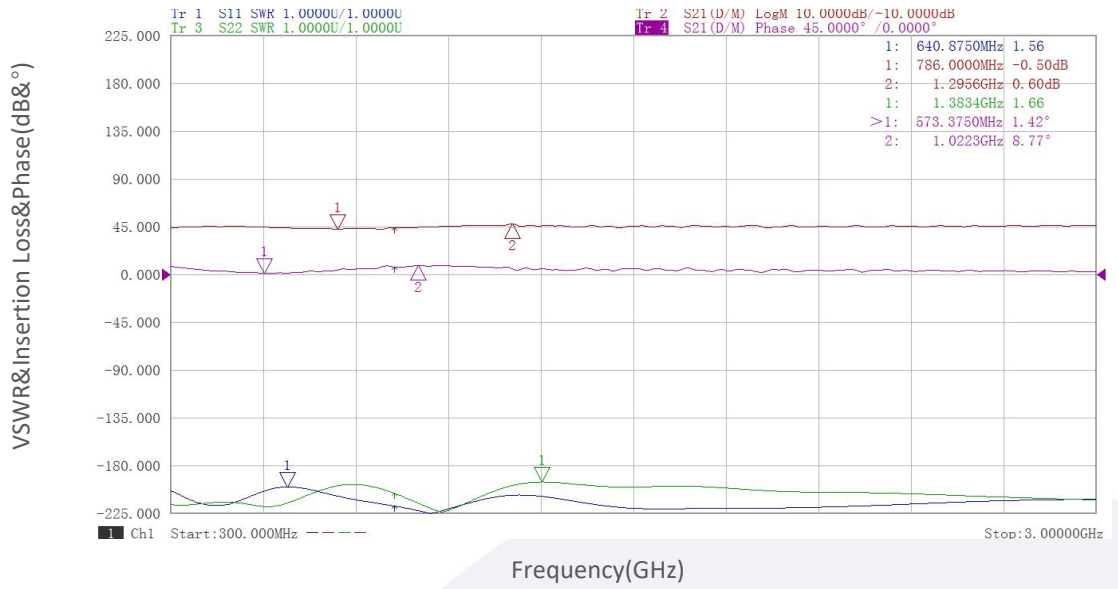

Note: Above data is for ref only, actual data may vary from unit to unit depending on operating environment and other factors like material lots etc.