

## Power Amplifier

1-18GHz/40dB Gain/34dBm Psat

Model: TLPA1G18G-40-34

TLPA1G18G-40-34 is a power amplifier with a minimum small signal gain of 40 dB and a nominal Psat of 34 dBm across the frequency range of 1 to 18 GHz. The DC power requirement for the amplifier is +20 VDC/0.8 A. The input and output port configuration offers coax adapter structure with SMA female.

### Features:

- Frequency range: 1-18GHz
- Gain: 40dB Min
- Output Power Psat: 34dBm Typ
- Good Power and Gain Flatness
- 50 Ohm Matched Input / Output

### Applications:

- Cellular
- PCN
- GSM
- ISM
- Lab Test

### 电气特性 Electrical Characteristics:

参数 Parameter	Min	Typ	Max	单位 Units
频率范围 Frequency range	1		18	GHz
小信号增益 Small Signal Gain	40	41		dB
增益平坦度 Gain Flatness		±2.5	±3	dB
线性输出功率 Output P1dB		31		dBm
饱和输出功率 Output Psat		34		dBm
杂散 Spurious@Psat		-60		dBc
输入驻波 Input VSWR		2	2.5	:1
输出驻波 Output VSWR		2	2.5	:1
直流电压 DC Voltage		+20		V DC
直流电流 DC Supply Current		0.8		A
阻抗 Impedance		50		Ohms

## 机械特性 Mechanical Specifications:

参数 Parameter	指标 Value	单位 Units
输入/输出接口 Input /Output Connector	SMA Female/SMA Female	
直流偏置 DC Bias	Solder Pin	
尺寸 Size	58.5*38*12	mm

## 绝对最大值 Absolute Maximum Ratings:

参数 Parameter	指标 Value
供电偏置电压 Supply Bias Voltage	TBD
输入功率 RF Input Power	+5 dBm
ESD灵敏度 ESD sensitivity (HBm)	Class 0, passed 150V



## 外形图 Outline Drawing:

Unit:mm

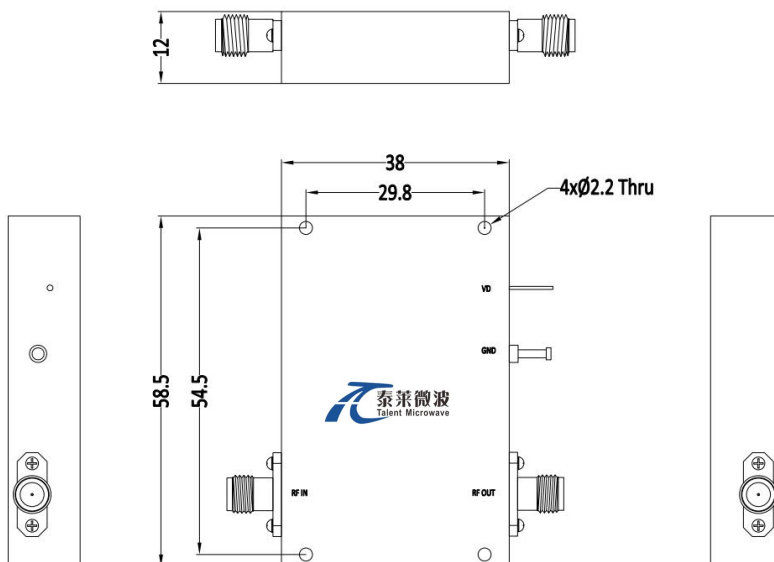

**\*\*\*Heat Sink Required During Operation**



ESD Protection: Strictly adhere to ESD precautions to prevent electrostatic damage.

## 温度环境 Environmental Conditions:

参数 Parameter	Min	Typ	Max	单位 Units
操作温度 Operating Temperature*	-40		+60	°C
存储温度 Non-operating Temperature*	-50		+70	°C
相对湿度 Relative humidity		95		%
海拔 Altitude		10,000		feet
震动 Shock / Vibration(MIL-STD-810F)	25g rms (15 degree 2KHz) endurance, 1 hour per axis			
冲击 Shock(non operating)	20G for 11msc half sin wave,3 axis both directions			

\*Note: For a wider temperature range, please consult the manufacturer.

## 订货信息 Ordering Information:

标准型号 Base Number	描述 Description	版本号 Revision
TLPA1G18G-40-34	Power amplifier 1-18GHz, Gain:40dB,Psat:34dBm,+20V DC,Without Heatsink	Rev.1.1
TLPA1G18G-40-34-HS	Power amplifier 1-18GHz, Gain:40dB,Psat:34dBm,+20V DC,With Heatsink	Rev.1.1

## 典型曲线 Typical Performance Data:

### VSWR&Gain vs Frequency

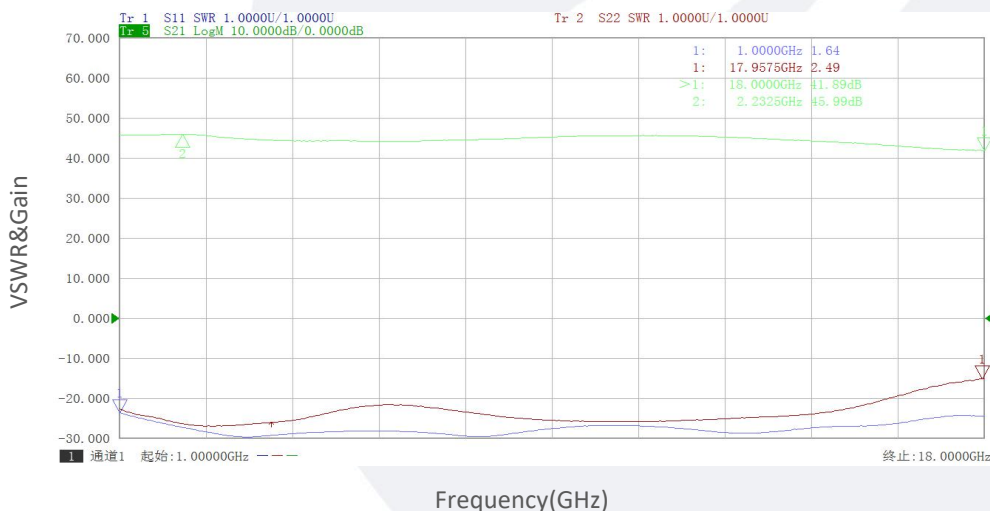

Note: Above data is for ref only, actual data may vary from unit to unit depending on operating environment and other factors like material lots etc.

典型曲线 Typical Performance Data:

Gain vs Output Power

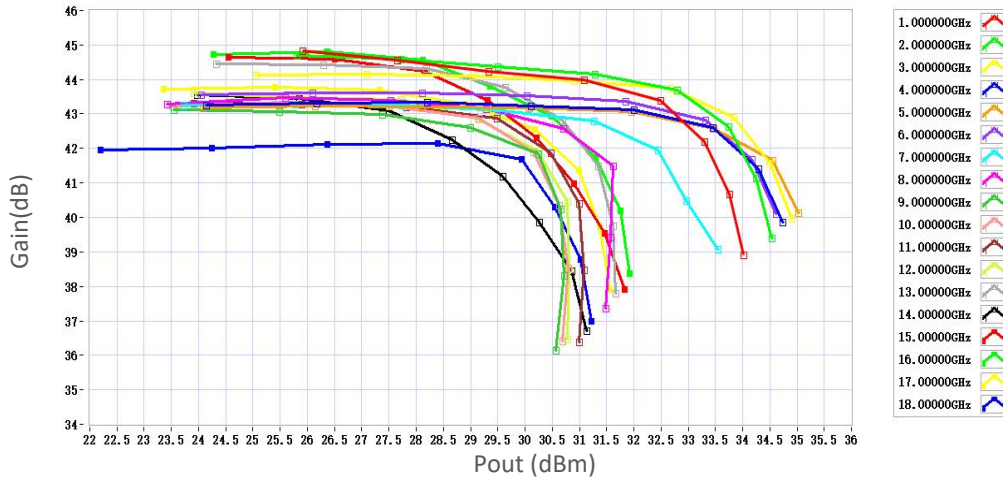

Gain vs Frequency

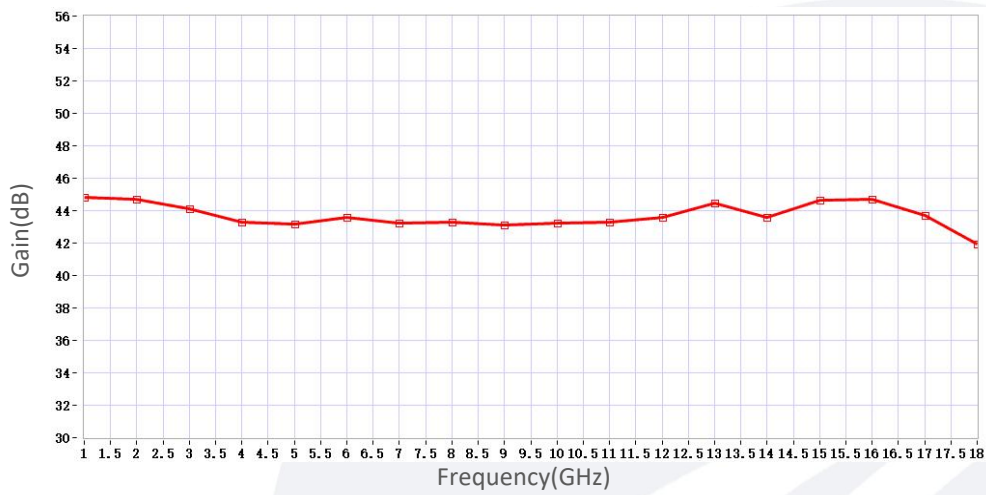

P1dB vs Frequency

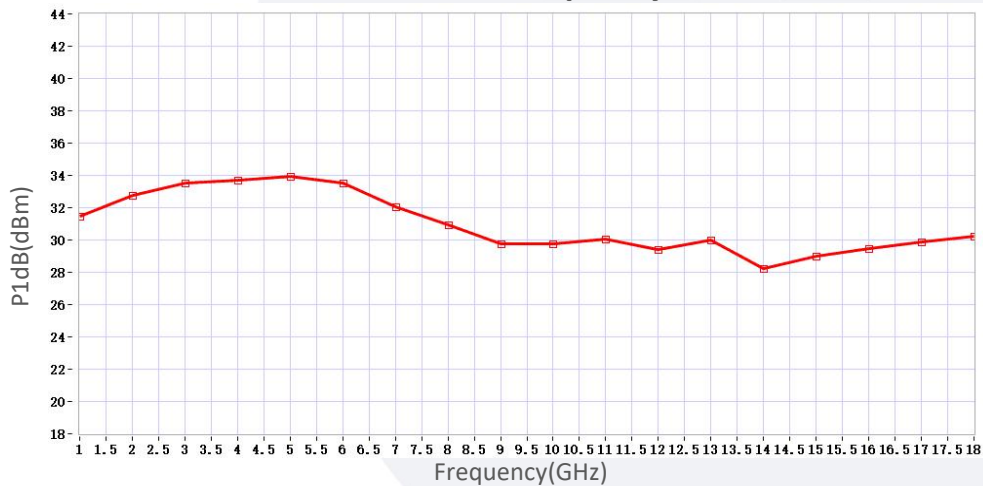

Note: Above data is for ref only, actual data may vary from unit to unit depending on operating environment and other factors like material lots etc.

## 典型曲线 Typical Performance Data:

### P3dB vs Frequency

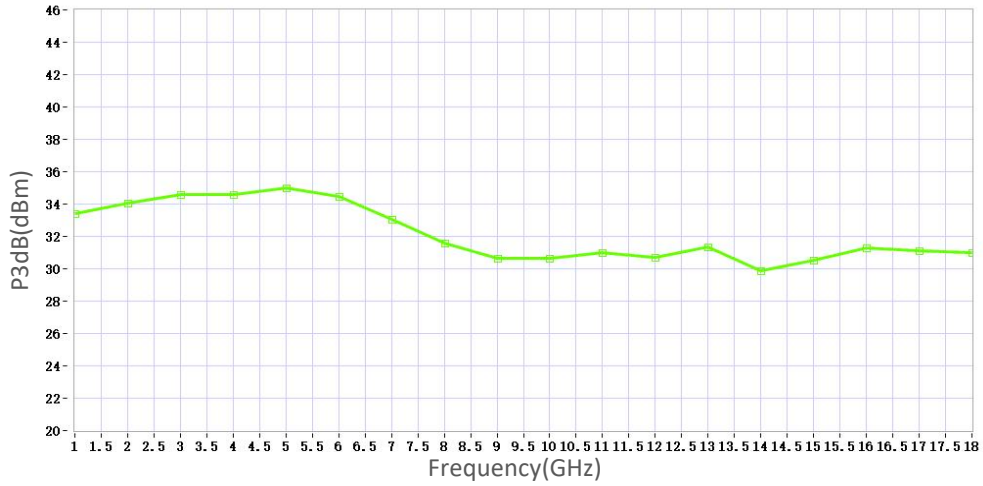

Note: Above data is for ref only, actual data may vary from unit to unit depending on operating environment and other factors like material lots etc.