

Solid State High Power Amplifier Systems

26.5-40GHz/57dB Gain/57dBm Psat/380V AC

Model: TLPA26.5G40G-57-57-BC

TLPA26.5G40G-57-57-BC is a solid state high power amplifier systems provides high output power and high gain across the 26.5 to 40 GHz frequency range. The amplifier features a built-in 380V power supply, making it easy to use in most lab environments. This model features thermal self protection, preventing damage to the amplifier and providing added reliability.

Features:

- Frequency range: 26.5-40GHz
- Gain: 57dB Min
- Psat Output Power: 57dBm Min
- Protection: Over TEM, over voltage, over current, over VSWR protection
- 50 Ohm Matched Input / Output

Electrical Characteristics:

Parameter	Symbol	Min	Typ	Max	Units
Frequency range	BW	26.5-40			GHz
Power Gain	GP	57			dB
Gain flatness	Δ GL		± 5		dB
Output Psat	Psat	57			dBm
Spurious	Spur			-60	dBc
Harmonics	HAM			-20	dBc
Input VSWR	VSWR _{in}			2.0	:1
AC Voltage	Vac		380		V AC
Power Consumption	P _{diss}			12500	W
Impedance	I/O-IMP	50			Ohms

Mechanical Specifications:

Parameter	Value	Units
Input /Output Connector	2.92mm Female/WR28	
Forward/Reverse Coupling	2.92mm Female/2.92mm Female	
Communication Connector	DB9/RJ45	
Front Panel LCD Screen Display	7 inch LCD Screen Display	
Size	20U	
Weight	≤ 250	Kg

Absolute Maximum Ratings:

Parameter	Value
RF Input Power	0 dBm
ESD sensitivity (HBM)	Class 0, passed 150V

Outline Drawing:

Unit:mm

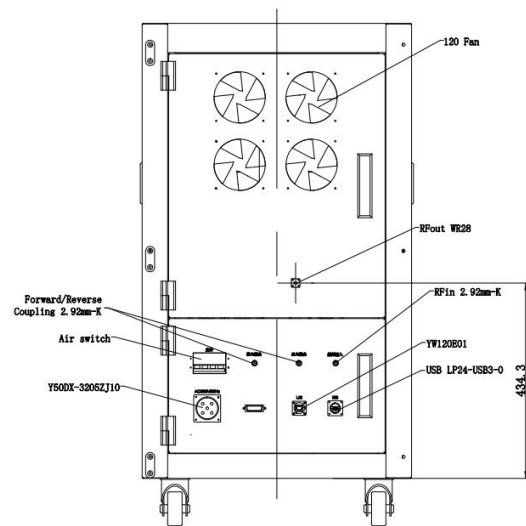
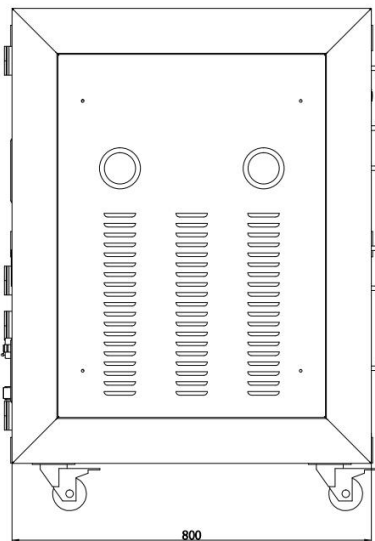
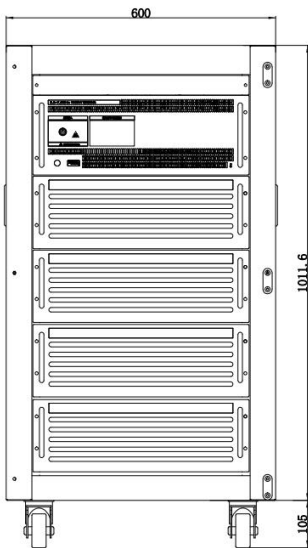

Key Features:

Parameter	Advantages
Control functions	1, Power setting On/Off 2, ALC automatic level control
Protection functions	1, Over TEM 2, Over voltage 3, Over current 4, Over VSWR
Remote control	RS422/LAN
Cooling system	Built in Cooling system, forced air cooling

Environmental Conditions:

Parameter	Min	Typ	Max	Units
Operating Temperature*	-20		+40	°C
Non-operating Temperature*	-30		+50	°C
Relative humidity		95		%
Altitude	10,000			feet
Shock / Vibration(MIL-STD-810F)	25g rms (15 degree 2KHz) endurance, 1 hour per axis			
Shock(non operating)	20G for 11msec half sin wave,3 axis both directions			

*Note: For a wider temperature range, please consult the manufacturer.

Ordering Information:

Base Number	Description	Revision
TLPA26.5G40G-57-57-BC	Solid State High Power Amplifier Systems 26.5-40GHz, Gain:57dB, Psat:57dBm, 380V AC, Built in Fan Cooling	Rev.1.1

Typical Performance Data:

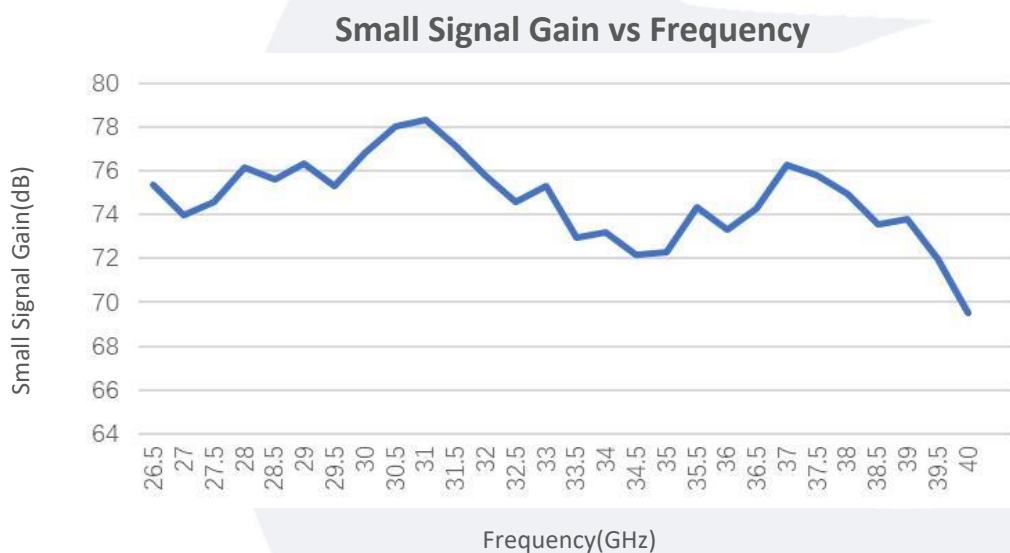

Note: Above data is for ref only, actual data may vary from unit to unit depending on operating environment and other factors like material lots etc.

Typical Performance Data:

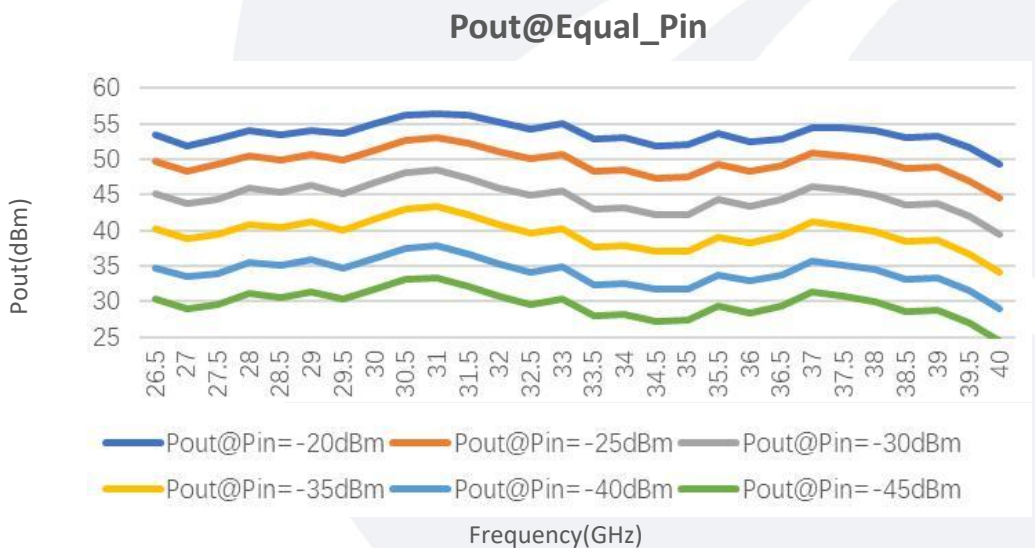
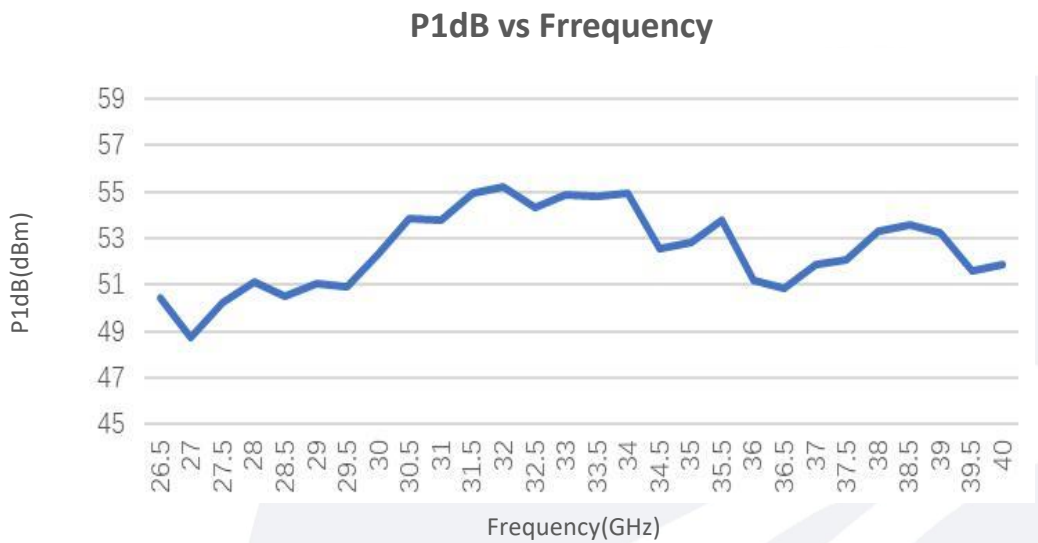
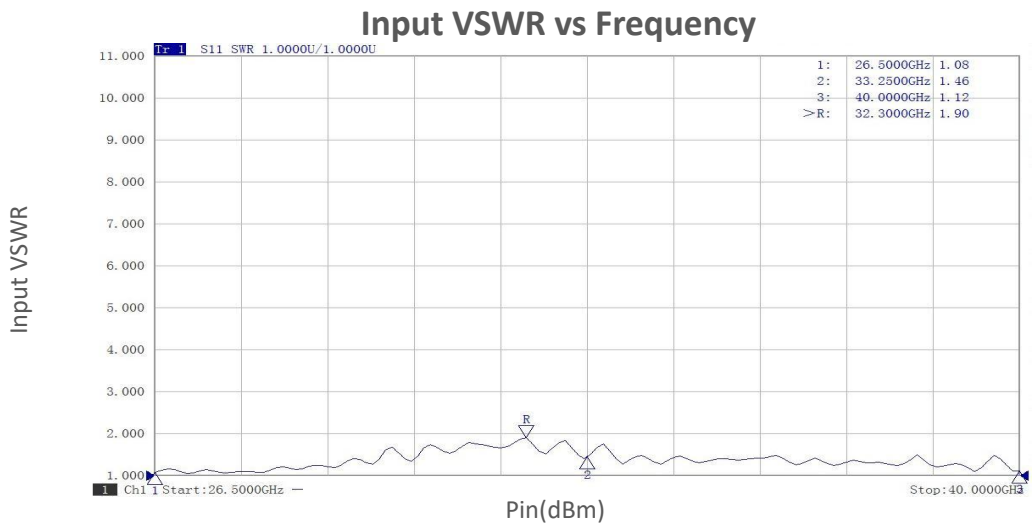

Note: Above data is for ref only, actual data may vary from unit to unit depending on operating environment and other factors like material lots etc.

Typical Performance Data:

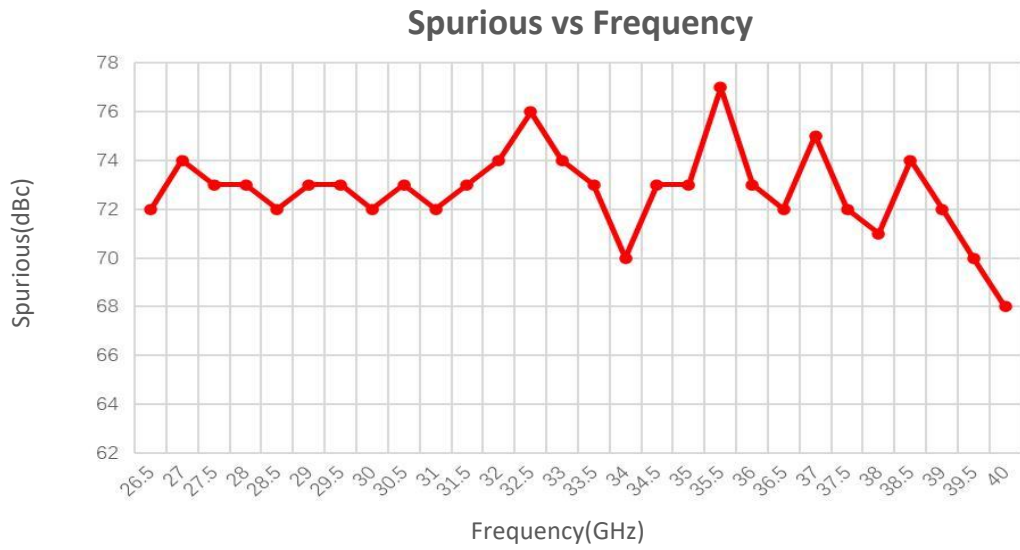

Note: Above data is for ref only, actual data may vary from unit to unit depending on operating environment and other factors like material lots etc.