

R Series

Semi-Flexible Cable

09

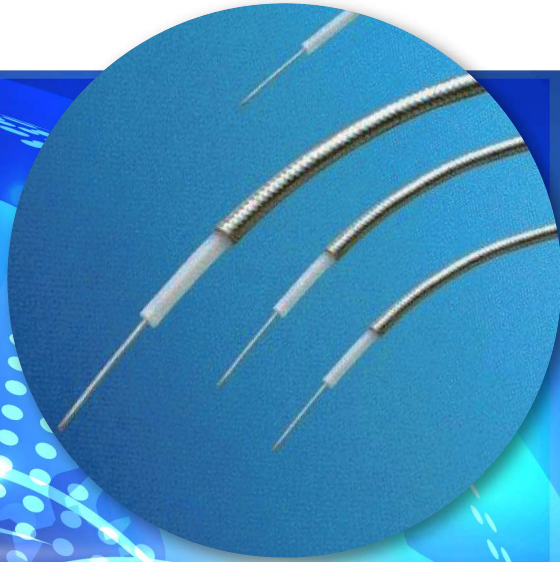

INTRODUCTION

R series adopts high-density round wire knit tinning structure as its outer conductor. Due to nearly 100% coverage after tin-plating on shielding layer, which makes the cable with good shielding, higher operating frequency and good electrical performance. The shielding layer after tin-plating has good bending formability and is suitable for repeated bending with certain forming adjustment. It is often used to replace semi-rigid cable. In terms of electrical performance, it has high operating frequency, low VSWR and good shielding. In terms of mechanical property, the outer conductor of high-density round wire knit tinning enables the cable strong tensility and good bending formability. In terms of environmental resistance, due to the characteristics of the raw materials of the inner and outer conductors and insulating layers, the cable has strong environmental adaptability ($-65^{\circ}\text{C} \sim +165^{\circ}\text{C}$), corrosion resistance and mold resistance. But different outer sheathing materials also determine different environmental adaptability.

Typical Application

- Aerospace
- Plate-to-plate connection
- Instrumentation and card interconnection
- Feed network

Features

- Ultra-low loss
- Light weight
- High power resistance
- High temperature resistance
- Good temperature and phase stability

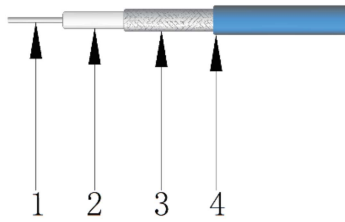

- 1—Center Conductor——SPC(Silver Plated Copper)
- 2—Dielectric——PTFE
- 3—Outer Conductor——Knit+Wicking
- 4—Jacket——FEP (Optional)

Cable Specification

Model	R1		R2		R3		R4	
Mechanical Specifications								
Center Conductor (mm)	0.29		0.51		0.92		1.65	
Dielectric (mm)	0.94		1.68		2.98		5.25	
Outer Conductor (mm)	1.19		2.17		3.55		6.30	
Jacket (mm)	1.60		2.50		4.20		7.00	
Electrical Specifications								
Impedance(Ω)	50		50		50		50	
Velocity of Propagation(%)	70		70		70		70	
Shielding Effectiveness (dB)	< -100		< -100		< -100		< -100	
Time Delay (ns/m)	4.76		4.76		4.76		4.76	
Capacitance (pF/m)	95.2		95.2		95.2		95.2	
Cut-off Frequency(GHz)	109		60		34		19	
Voltage Withstand(V,DC)	500		1000		1500		2000	
Static Bending Radius (mm)	6		11		18		32	
Operating Temperature (°C)	-55~125		-55~125		-55~125		-55~125	
Attenuation(+25°C Ambient)&Power Handling(+40°C Ambient;SeaLevel;VSWR 1:1)								
Frequency (MHz)	dB/100m		KW		dB/100m		KW	
500	83.94		0.0540		48.19		0.144	
1000	119.76		0.0378		69.30		0.100	
2000	171.47		0.0264		100.31		0.069	
4000	246.68		0.0184		146.47		0.047	
6000	306.07		0.0148		183.73		0.038	
8000	357.25		0.0112		216.37		0.028	
12000	445.42		0.0102		273.66		0.025	
16000	522.00		0.0087		324.44		0.021	
18000	557.35		0.0081		348.17		0.020	
20000	591.17		0.0077		371.05		0.019	
26500	692.94		0.0065		440.80		0.016	
40000	877.98		0.0052		570.87		0.012	
50000	1000.51		0.0045					
K1	3.6740161		2.0669291		1.0824		0.688976	
K2	0.0035795		0.003937		0.003937		0.003937	

Test Data

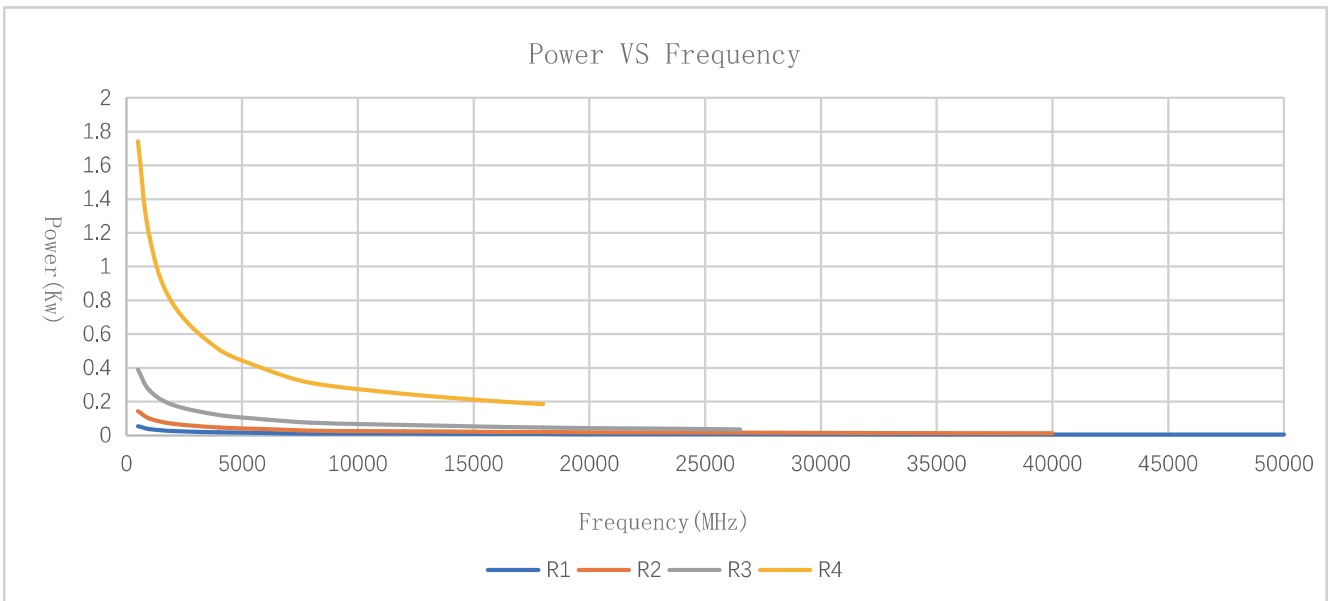
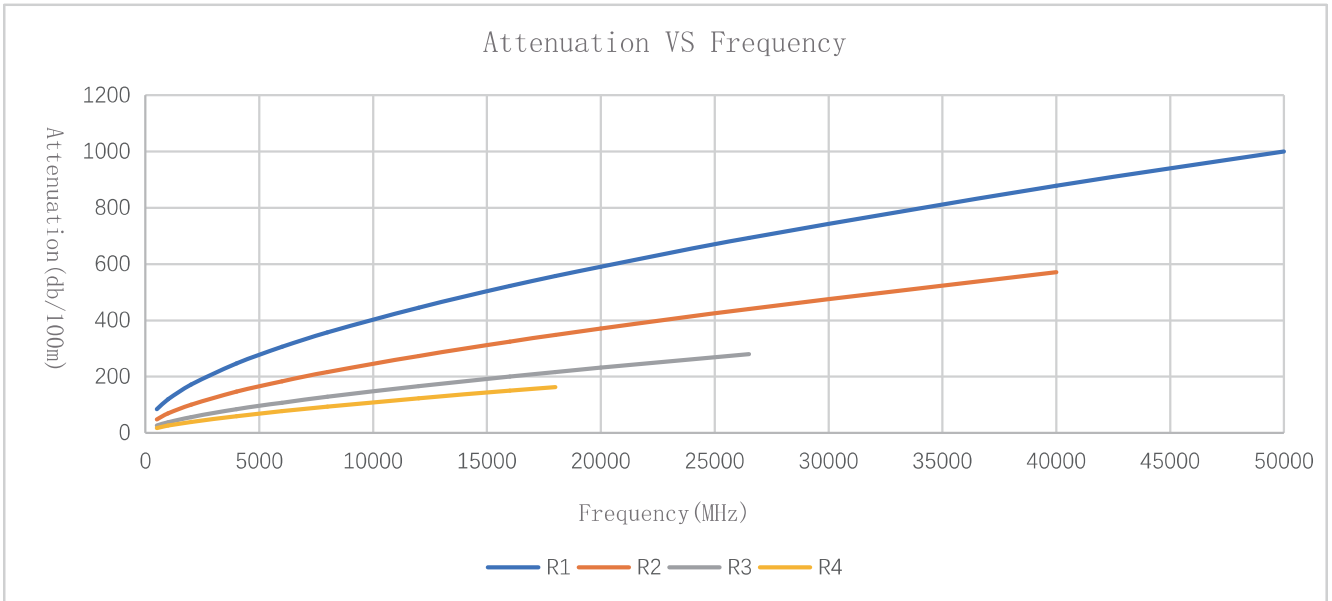

Assembly Selection Information

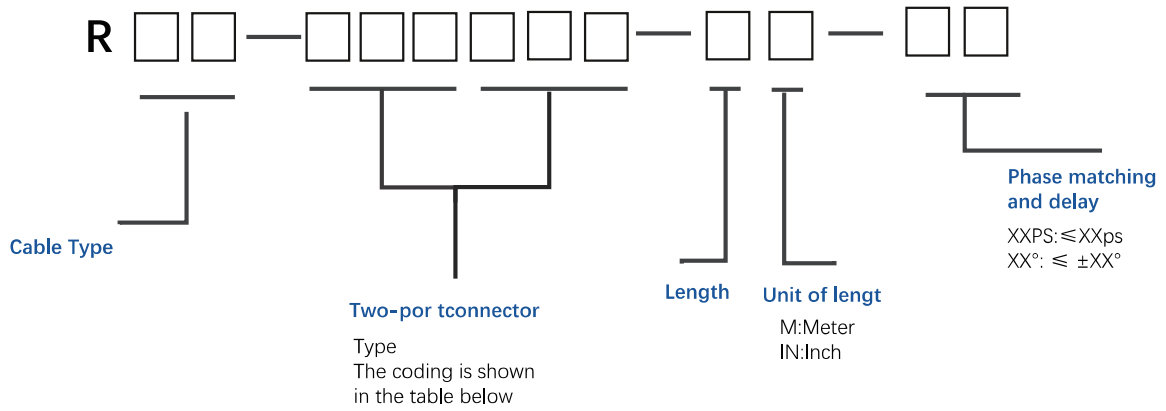

Optional Connectors

Connector Code	Connector Type	Operating Frequency	R1	R2	R3	R4	VSWR (Max)
1.85M	1.85mm Male	DC-40GHz		●			
2.92M	2.92mm Male	DC-40GHz	●	●			1.30
2.92F	2.92mm Female	DC-40GHz	●	●			1.30
SSMAM	SSMA Male	DC-40GHz		●			1.30
3.5M	3.5mm Male	DC-27GHz			●		1.30
SMAM	SMA Male	DC-27GHz		●	●	●	1.25
SMAWM	SMA Male Right Angle	DC-18GHz		●	●		1.25
SMAF	SMA Female	DC-27GHz		●		●	1.25
NM	N Male	DC-18GHz		●	●	●	1.25
NF	N Female	DC-18GHz		●	●	●	1.25
TNCM	TNC Male	DC-12GHz		●			1.25
SMPF	SMP Female	DC-40GHz		●			1.25
SSMPF	SSMP Female	DC-40GHz		●			1.25