

## Waveguide to Coax Adapter, End Launch

### WR-10/1.0mm Male/75-110GHz

**Model: TL-10WCA1.0ME-CU**

The TL-10WCA1.0ME-CU is end launch waveguide to coax adapters that cover the frequency range of 75 to 110 GHz. It is designed for an efficient transition between the rectangular waveguide and 1.0 mm coax connector.

#### Features:

- Operating Frequency 75 to 110GHz
- Lower Insertion Loss and VSWR
- Instrumentation Grade
- DC Short Circuit

#### Applications:

- Test Lab
- Instrumentations
- Sub-assemblies

### 电气特性 Electrical Characteristics:



参数 Parameter	Min	Typ	Max	单位 Units
频率范围 Frequency Range	75		110	GHz
驻波 VSWR		1.3		:1
插损 Insertion Loss		0.5		dB
耐功率 Power Handling			2	W

### 环境和机械特性 Environmental And Physical Characteristics:

类型 Description	参数 Parameter	单位 Units
操作温度 Operating Temperature	-40 To +85	°C
存储温度 Storage Temperature	-40 to +85	°C
材质 Material	Copper	
表面处理 Finish	Gold Plated	
同轴接口 Coax Connector	1.0mm Male	
波导 Waveguide	WR-10/UG-387/U-M	

**外形图 Outline Drawing:**

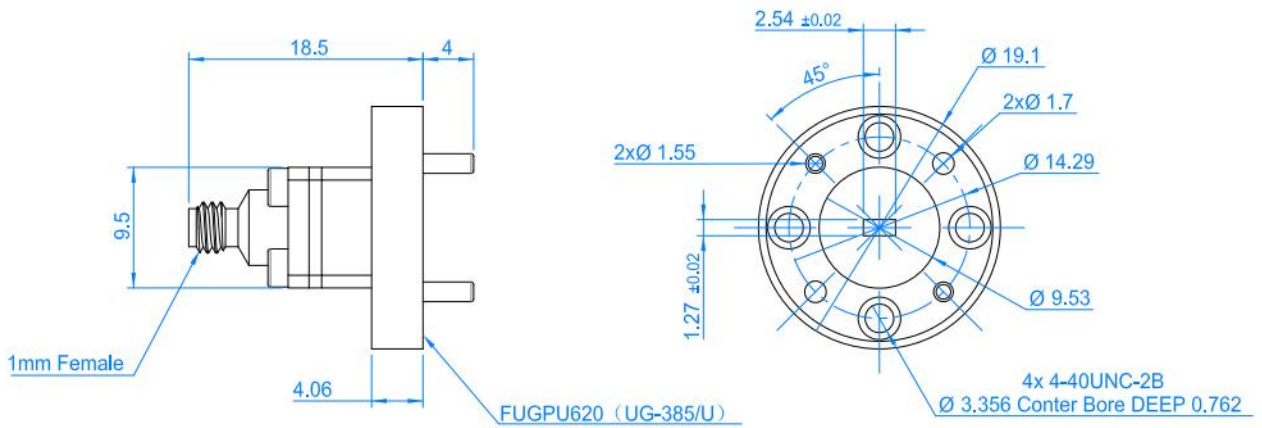
Unit:mm

ESD Protection: Strictly adhere to ESD precautions to prevent electrostatic damage.

**订货信息 Ordering Information:**

标准型号 Base Number	描述 Description	版本号 Revision
TL-10WCA1.0ME-CU	Waveguide to Coax Adapter, End Launch WR-10/1.0mm Male,75-110GHz	Rev.1.1

**典型曲线 Typical Performance Data:**

**VSWR vs Frequency**

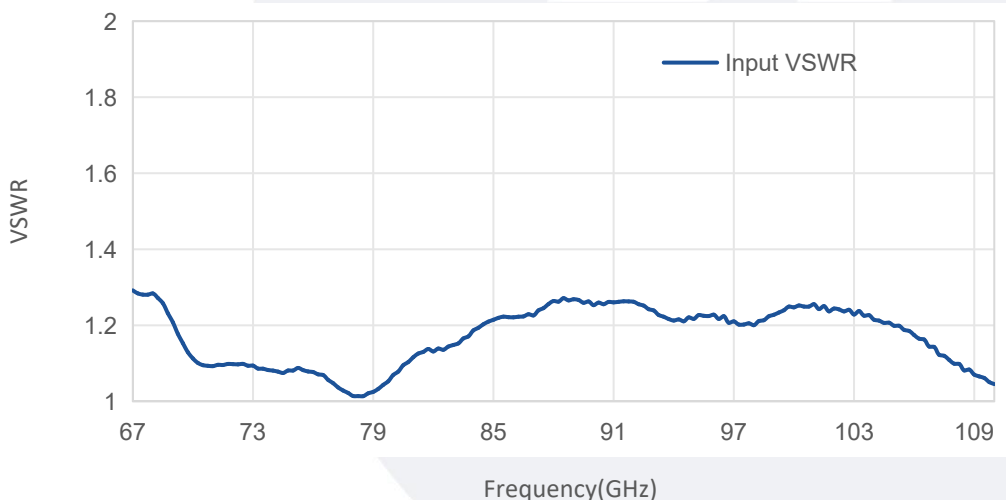

Note: Above data is for ref only, actual data may vary from unit to unit depending on operating environment and other factors like material lots etc.

## 典型曲线 Typical Performance Data:

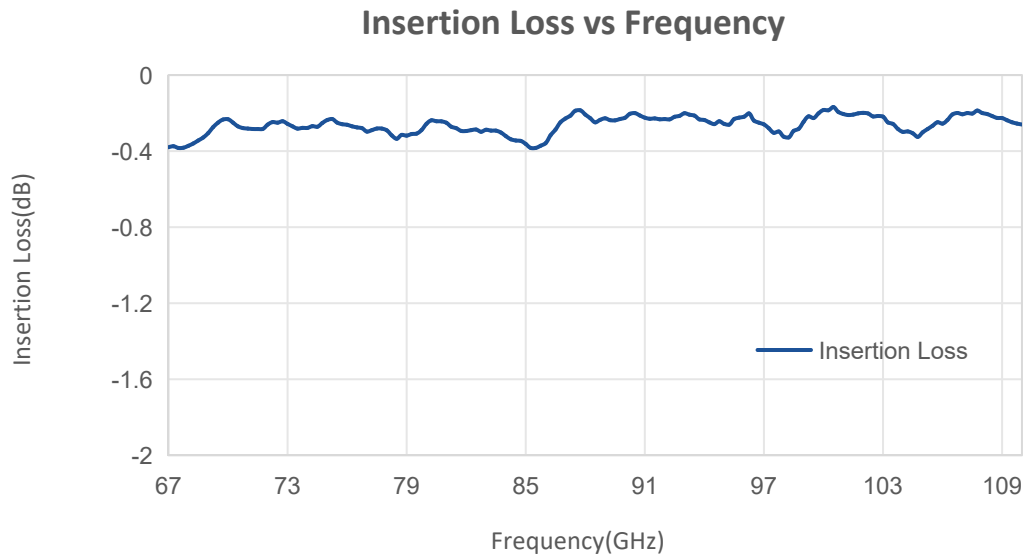

Note: Above data is for ref only, actual data may vary from unit to unit depending on operating environment and other factors like material lots etc.