

Model: TLHM-170260-0240-04
Sub-Harmonic Mixer
RF:170-260 GHz,LO:85-130GHz,IF:DC-40 GHz
Feature:

- Low LO Power Requirement
- Subharmonic Mixing
- Compact Package

电气特性 Electrical Specifications:

参数Parameter	Min	Typ	Max	单位Units
RF频率 RF Frequency	170		260	GHz
LO频率 LO Frequency	85		130	GHz
IF频率 IF Frequency	DC		40	GHz
LO 驱动功率 LO-Input power	6	8	10	dBm
射频输入功率 RF Input Power			0	dBm
RF驻波 RF VSWR		3		:1
单边带变频损耗 SSB Conversion Loss		-12		dB

机械特性 Mechanical Specifications:

参数Parameter	指标 Value	单位Units
RF 接口RF Connector	WR-4.3/UG-387	
LO 接口LO Connector	WR-08/UG-387	
IF 接口 IF Connector	2.92mm Female	
尺寸 Size	25*27.1*19.1	mm

绝对最大值 Absolute Maximum Ratings:

参数Parameter	指标 Value
RF 功率 RF Input Power	0dBm
LO功率 LO Input Power	11dBm
ESD灵敏度 ESD sensitivity (HBm)	Class 0, passed 150V

外形尺寸 Outline Drawing:

Unit: mm

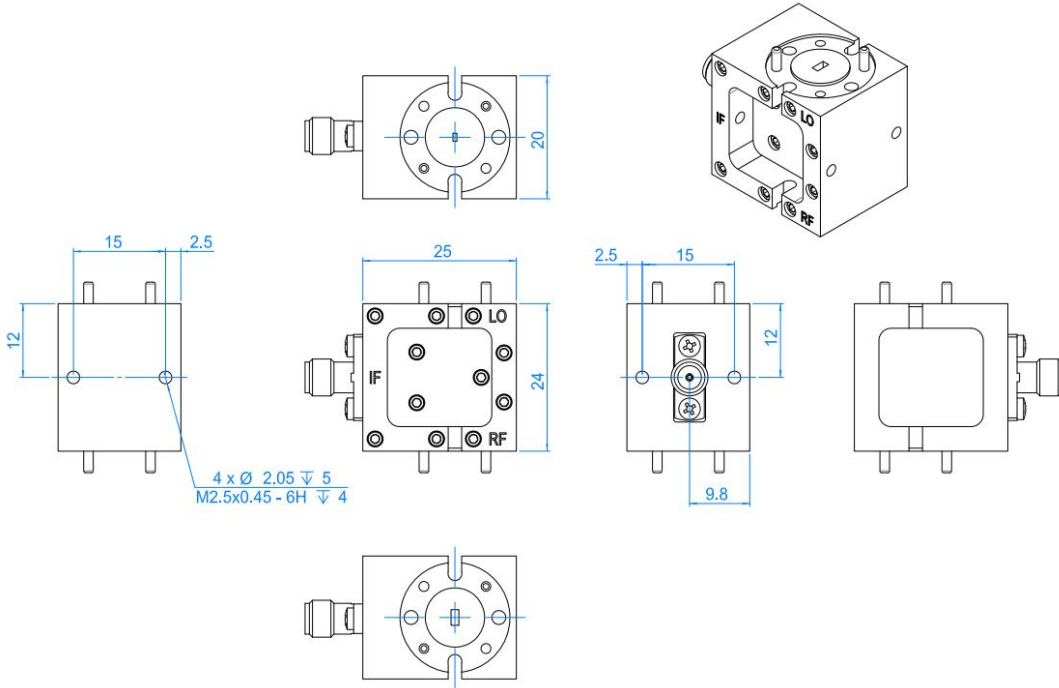

OBSERVE PRECAUTIONS
ELECTROSTATIC SENSITIVE
DEVICES

温度环境 Environmental Conditions:

参数Parameter	Min	Typ	Max	单位Units
操作温度 Operating Temperature	0		+40	°C
存储温度 Non-operating Temperature	-25		+65	°C
相对湿度 Relative humidity		95		%
海拔 Altitude	50,000			feet
震动 Shock / Vibration(MIL-STD-810F)	25g rms (15 degree 2KHz) endurance, 1 hour per axis			
冲击 Shock(non operating)	20G for 11msc half sin wave,3 axis both directions			

订货信息 Ordering Information:

标准型号 Part Number	描述 Description	版本号Revision
TLHM-170260-0240-04	Subharmonically Mixer RF:170-260GHz,LO:85-130GHz,IF:DC-40GHz	Rev.1.1

典型曲线 Typical Performance Data:

Conversion Loss vs RF Frequency

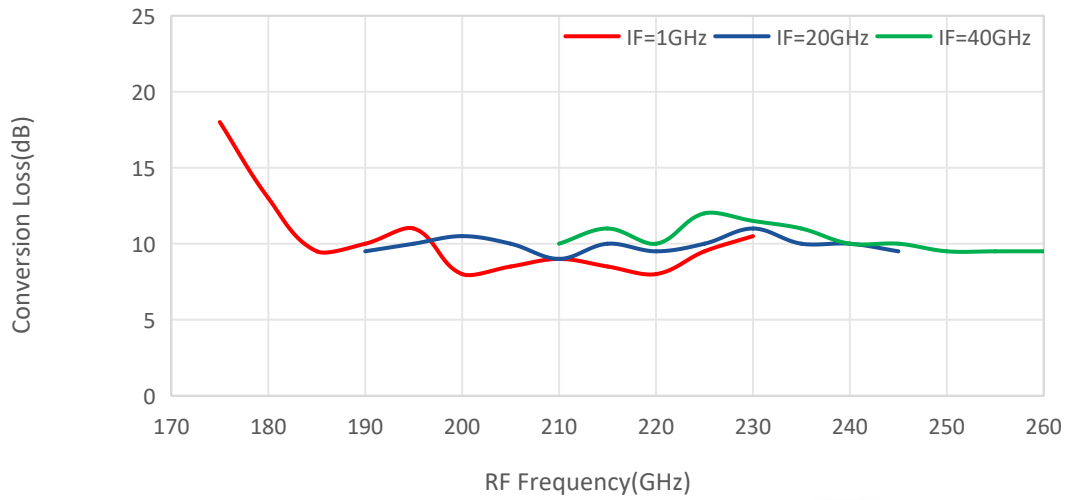

Conversion Loss vs RF Frequency

