

Model: TLHM-90140-0225-08
Sub-Harmonic Mixer
RF:90-140 GHz,LO:45-70GHz,IF:DC-25 GHz
Feature:

- Low LO Power Requirement
- Subharmonic Mixing
- Compact Package

电气特性 Electrical Specifications:

参数 Parameter	Min	Typ	Max	单位 Units
RF频率 RF Frequency	90		140	GHz
LO频率 LO Frequency	45		70	GHz
IF频率 IF Frequency	DC		25	GHz
LO 驱动功率 LO-Input power		7		dBm
射频输入功率 RF Input Power		-15	0	dBm
2XLO至RF隔离 2XLO to RF Isolation		-20		dBc
单边带变频损耗 SSB Conversion Loss	-10	-8	-6	dB

机械特性 Mechanical Specifications:

参数 Parameter	指标 Value	单位 Units
RF 接口 RF Connector	WR-08/UG-387	
LO 接口 LO Connector	WR-15/UG-385	
IF 接口 IF Connector	2.92mm Female	
壳体材质 Shell Material	Copper	
表面处理 Finish	Gold Plated	
尺寸 Size	24*20*20	mm

绝对最大值 Absolute Maximum Ratings:

参数 Parameter	指标 Value
RF 功率 RF Input Power	0 dBm
IF 功率 IF Input Power	0 dBm
LO 功率 LO Input Power	+15 dBm
ESD灵敏度 ESD sensitivity (HBm)	Class 0, passed 150V

外形尺寸 Outline Drawing:

Unit: mm

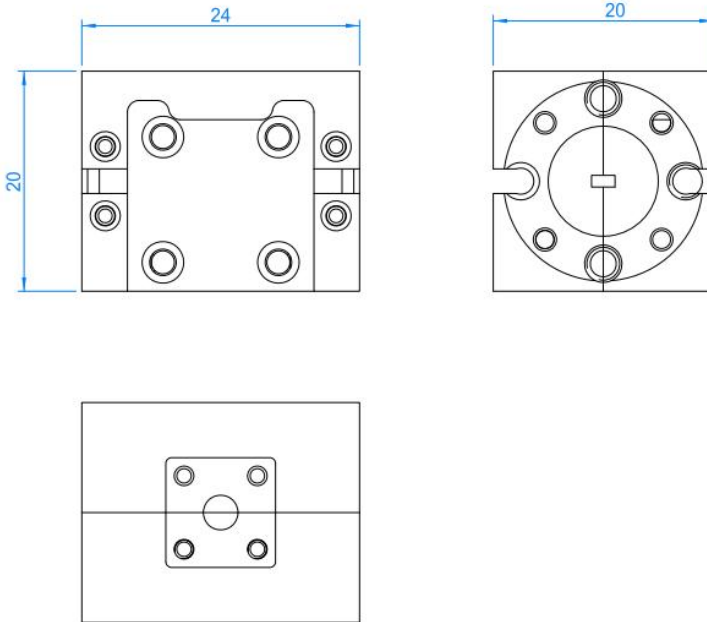
温度环境 Environmental Conditions:

参数 Parameter	Min	Typ	Max	单位 Units
操作温度 Operating Temperature	0		+50	°C
存储温度 Non-operating Temperature	-45		+85	°C
相对湿度 Relative humidity		95		%
海拔 Altitude	10,000			feet
震动 Shock / Vibration(MIL-STD-810F)	25g rms (15 degree 2KHz) endurance, 1 hour per axis			
冲击 Shock(non operating)	20G for 11msc half sin wave,3 axis both directions			

订货信息 Ordering Information:

标准型号 Part Number	描述 Description	版本号 Revision
TLHM-90140-0225-08	Subharmonically Mixer RF:90-140GHz,LO:45-70GHz,IF:DC-25GHz	Rev.1.1

典型曲线 Typical Performance Data(Test Data=25°C) :

SSB Conversion Loss vs RF Frequency

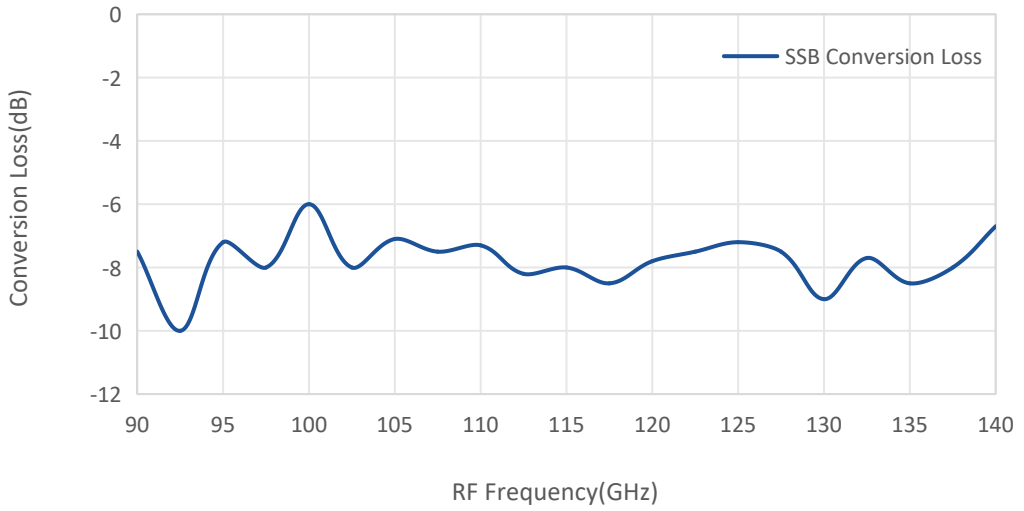

Note: Above data is for ref only, actual data may vary from unit to unit depending on operating environment and other factors like material lots etc.