

Model: TMPA-070110-1720-10
Power Amplifier
70-110 GHz, Gain:17 dB, Psat:21 dBm
Feature:

- Frequency Range:70-110 GHz
- Gain:17 dB Typ
- Output Power Psat:21 dBm Typ
- Good Power and Gain Flatness

电气特性 Electrical Specifications:

参数Parameter	Min	Typ	Max	单位Units
频率范围 Frequency range	70-110			GHz
增益 Gain		17		dB
增益平坦度 Gain Flatness		±1.5		dB
饱和输出功率 Output Psat		21		dBm
输入驻波 Input VSWR		2		:1
输出驻波 Output VSWR		1.5		:1
直流电压 DC Voltage		12		V DC
直流电流 DC Supply Current		400		mA

机械特性 Mechanical Specifications:

参数Parameter	指标 Value	单位Units
输入输出接口 Input /Output Connector	WR-10/UG-387/U	
直流偏置 DC Bias	Solder Pin	
尺寸 Size	40*50*20	mm
重量 Weight	/	g

绝对最大值 Absolute Maximum Ratings:

参数Parameter	指标 Value
供电偏置电压 Supply Bias Voltage	+15V
输入功率 RF Input Power	20 dBm
ESD灵敏度 ESD sensitivity (HBm)	Class 0, passed 150V

 Available 220V System
 Benchtop Amplifier

外形尺寸 Outline Drawing:

Unit: mm(Inches)

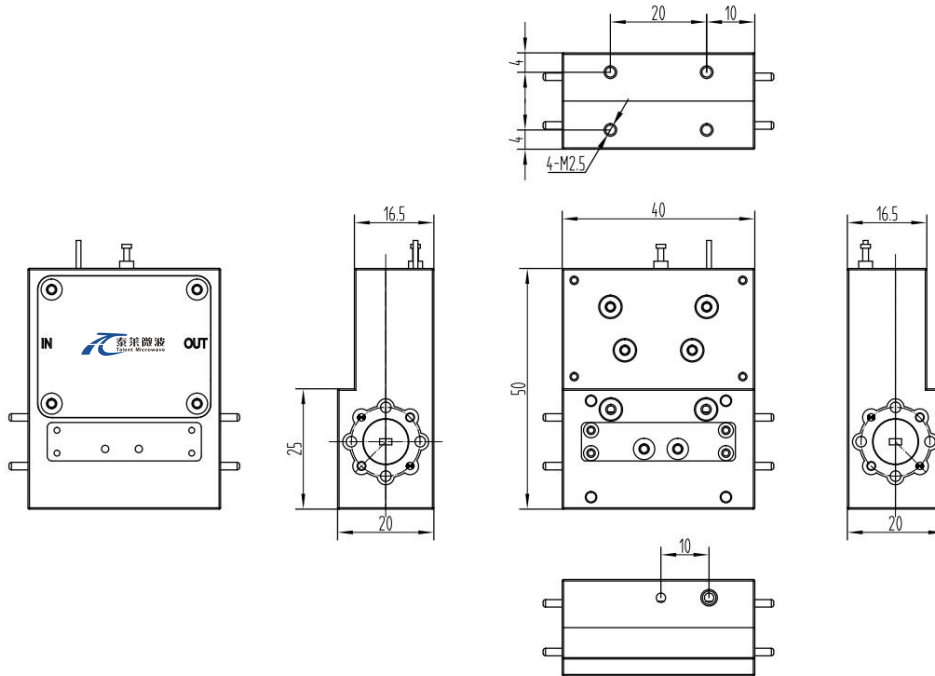

OBSERVE PRECAUTIONS
ELECTROSTATIC SENSITIVE
DEVICES

温度环境 Environmental Conditions:

参数 Parameter	Min	Typ	Max	单位 Units
操作温度 Operating Temperature	-45		+85	°C
存储温度 Non-operating Temperature	-55		+125	°C
相对湿度 Relative humidity		95		%
海拔 Altitude	10,000			feet
震动 Shock / Vibration(MIL-STD-810F)	25g rms (15 degree 2KHz) endurance, 1 hour per axis			
冲击 Shock(non operating)	20G for 11msc half sin wave, 3 axis both directions			

订货信息 Ordering Information:

标准型号 Part Number	描述 Description	版本号 Revision
TMPA-070110-1720-10	Power Amplifier, 70-110 GHz, Gain: 17 dB Typ, P _{sat} : 21 dBm Typ, +12V DC, WR-10	Rev.1.1

典型曲线 Typical Performance Data:

Gain vs Frequency

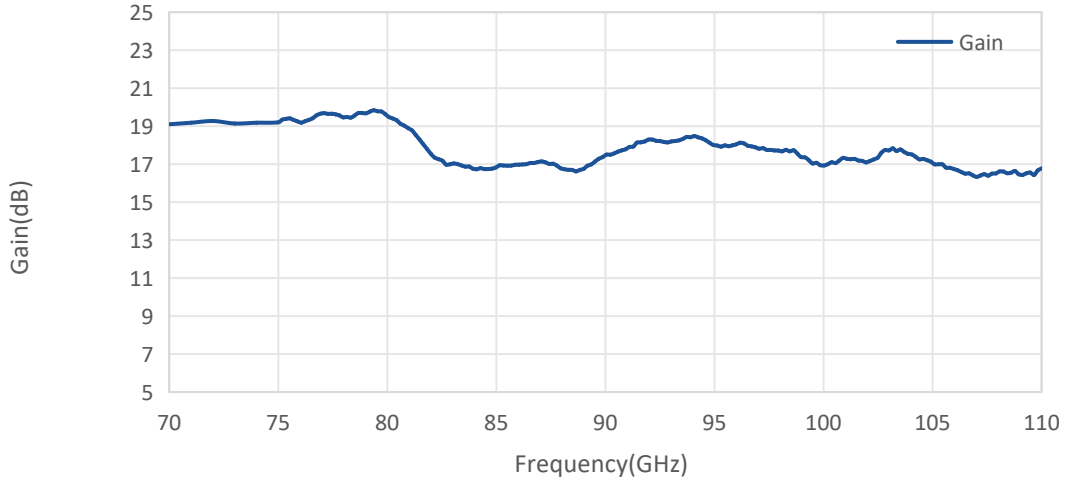

VSWR vs Frequency

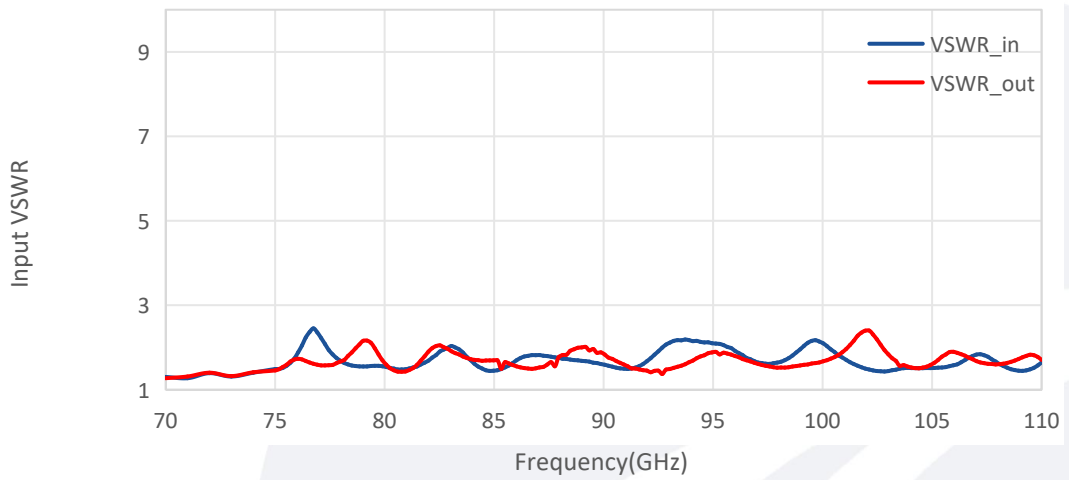

Psat vs Frequency

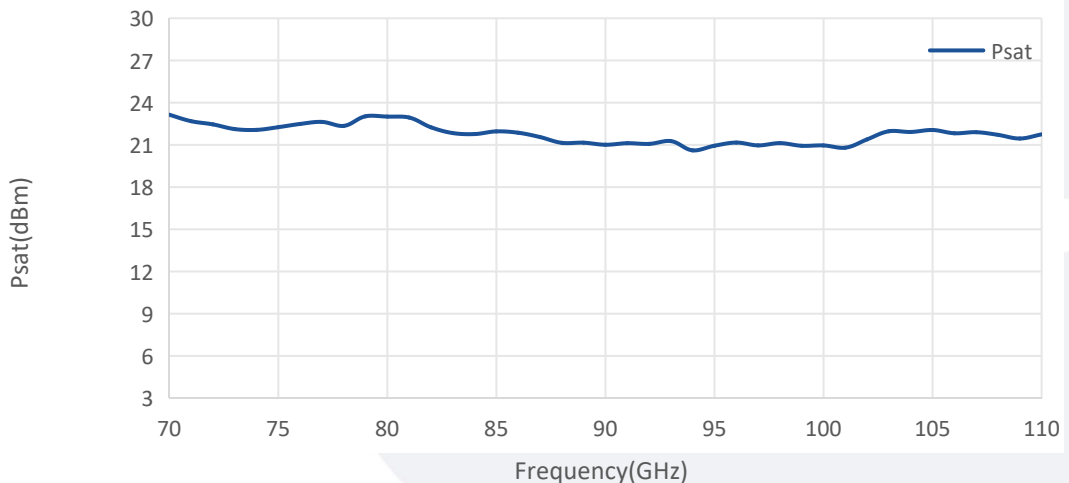

Note: Above data is for ref only, actual data may vary from unit to unit depending on operating environment and other factors like material lots etc.