

**Model: TMLA-050075-3840-15**
**Low Noise Amplifier**  
**50-75GHz, NF:4.0 dB, Gain:38 dB**
**Feature:**

- Ultra Wide Band: 50-75 GHz
- Gain: 38dB Typ
- Noise Figure: 4.0dB Typ
- Unconditional stability

**电气特性 Electrical Specifications:**

参数Parameter	Min	Typ	Max	单位Units
频率范围 Frequency range	50		75	GHz
增益 Gain		38		dB
噪声系数 Noise Figure		4.0		dB
输出功率1dB压缩点 Output P1dB		12		dBm
输入驻波 Input VSWR		2		:1
输出驻波 Output VSWR		2		:1
直流电压 DC Voltage		12		V DC
直流供电 DC power supply		150		mA

**机械特性 Mechanical Specifications:**

参数 Parameter	指标 Value	单位 Units
输入接口 Input Connector	WR-15/ UG-385/U	
输出接口 Output Connector	WR-15/ UG-385/U	
供电引脚 Power Supply Pin	Solder Pin	
尺寸 Size	45*30*23	mm

**绝对最大值 Absolute Maximum Ratings:**

参数 Parameter	指标 Value
供电偏置电压 Supply Bias Voltage	+15V
输入功率 RF Input Power	10 dBm
ESD灵敏度 ESD sensitivity (HBm)	Class 0, passed 150V

**Available 220V System  
 Benchtop Amplifier**

外形尺寸 Outline Drawing:

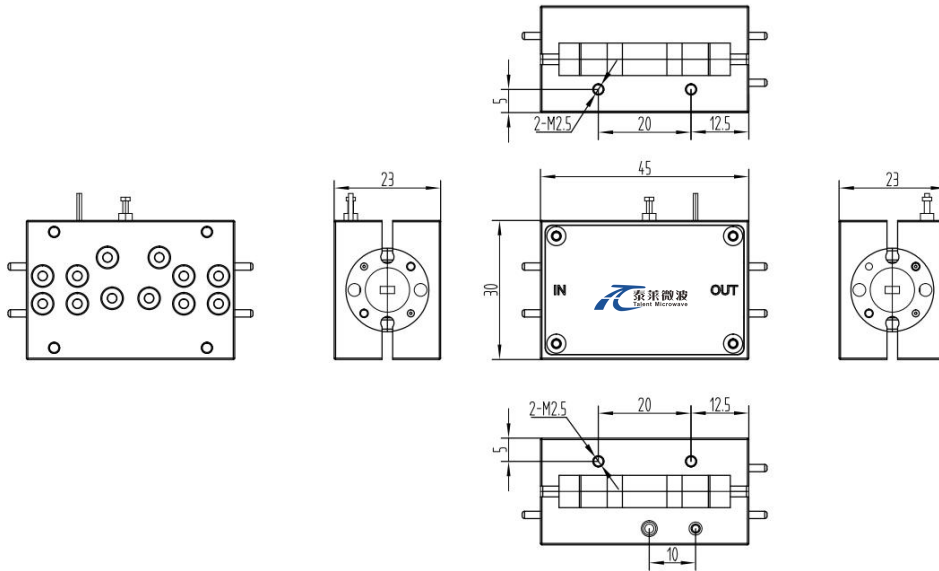

OBSERVE PRECAUTIONS  
ELECTROSTATIC SENSITIVE  
DEVICES

温度环境 Environmental Conditions:

参数 Parameter	Min	Typ	Max	单位 Units
操作温度 Operating Temperature	-55		+85	°C
存储温度 Non-operating Temperature	-45		+125	°C
相对湿度 Relative humidity		95		%
海拔 Altitude	50,000			feet
震动 Shock / Vibration(MIL-STD-810F)	25g rms (15 degree 2KHz) endurance, 1 hour per axis			
冲击 Shock(non operating)	20G for 11msc half sin wave,3 axis both directions			

订货信息 Ordering Information:

标准型号 Part Number	描述 Description	版本号 Revision
TMLA-050075-3840-15	Low Noise Amplifier,50-75GHz, Noise Figure:4.0dB, Gain:38dB,+12V DC,WR-15	Rev.1.1

典型曲线 Typical Performance Data:

Gain vs Frequency

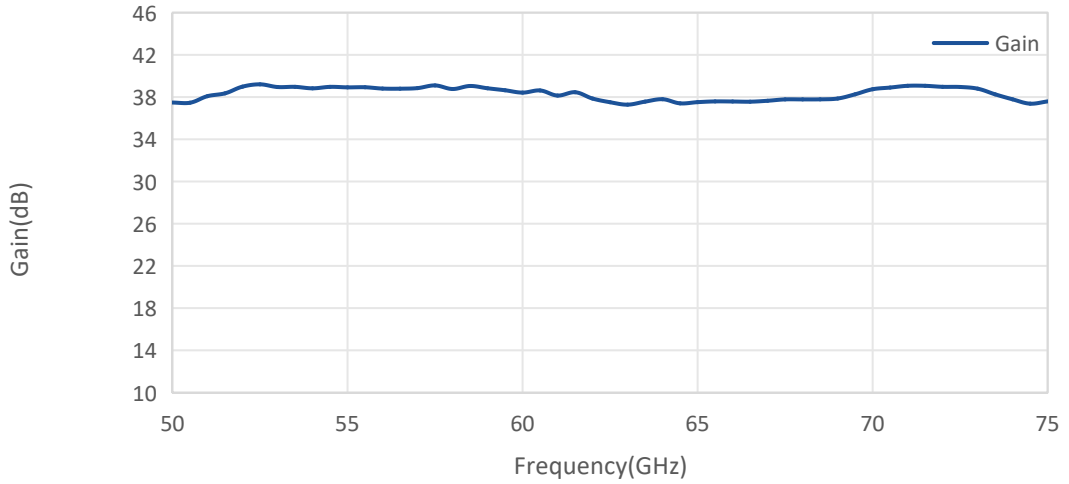

Note: Above data is for ref only, actual data may vary from unit to unit depending on operating environment and other factors like material lots etc.