

**Model: TMPA-075110-2515-10**
**Power Amplifier**
**75-110GHz, Gain:25 dB, Psat:15 dBm**
**Feature:**

- Frequency Range: 75-110 GHz
- Gain:25 dB Type
- Output Power Psat:15 dBm Type
- Good Power and Gain Flatness

**电气特性 Electrical Specifications:**

参数Parameter	Min	Typ	Max	单位Units
频率范围 Frequency range	75-110			GHz
小信号增益 Small Signal Gain		25		dB
饱和输出功率 Output Psat		15		dBm
输入驻波 Input VSWR		2		:1
输出驻波 Output VSWR		2		:1
直流电压 DC Voltage		12		V DC
直流电流 DC Supply Current		120		mA

**机械特性 Mechanical Specifications:**

参数 Parameter	指标 Value	单位 Units
输入/输出接口 Input /Output Connector	WR-10/UG-387/U	
直流偏置 DC Bias	Solder Pin	
尺寸 Size	39*30*23	mm
重量 Weight	/	g

**绝对最大值 Absolute Maximum Ratings:**

参数 Parameter	指标 Value
供电偏置电压 Supply Bias Voltage	+15V
输入功率 RF Input Power	TBD
ESD灵敏度 ESD sensitivity (HBm)	Class 0, passed 150V

**Available 220V System  
 Benchtop Amplifier**

外形尺寸 Outline Drawing:

Unit: mm

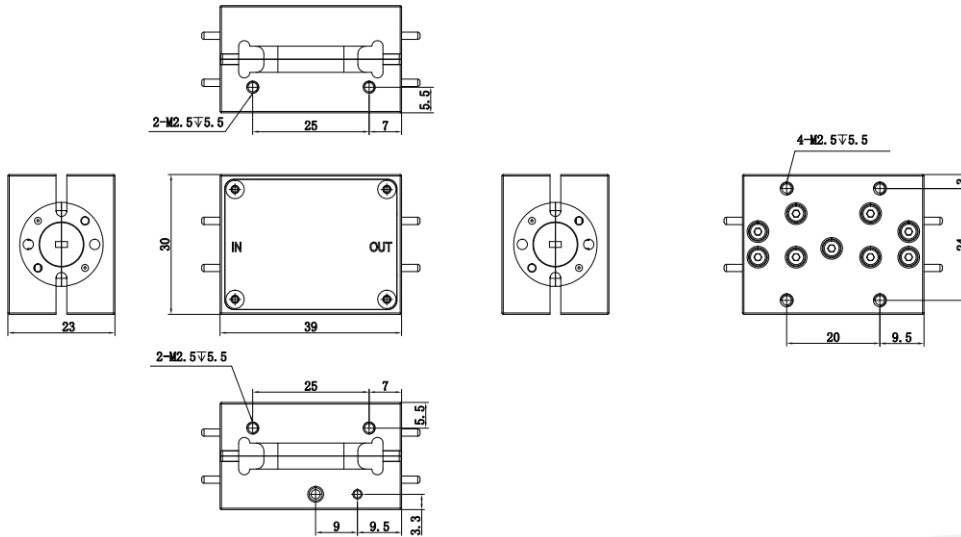

温度环境 Environmental Conditions:



OBSERVE PRECAUTIONS  
ELECTROSTATIC SENSITIVE  
DEVICES

参数 Parameter	Min	Typ	Max	单位 Units
操作温度 Operating Temperature	-10		+65	°C
存储温度 Non-operating Temperature	-55		+125	°C
相对湿度 Relative humidity		95		%
海拔 Altitude	50,000			feet
震动 Shock / Vibration(MIL-STD-810F)	25g rms (15 degree 2KHz) endurance, 1 hour per axis			
冲击 Shock(non operating)	20G for 11msc half sin wave,3 axis both directions			

订货信息 Ordering Information:

标准型号 Part Number	描述 Description	版本号 Revision
TMPA-075110-2515-10	Power Amplifier, 75-110 GHz, Gain:25 dB Type, Psat:15 dBm Type, 12V DC,WR-10	Rev.1.1

典型曲线 Typical Performance Data:

Gain vs Frequency

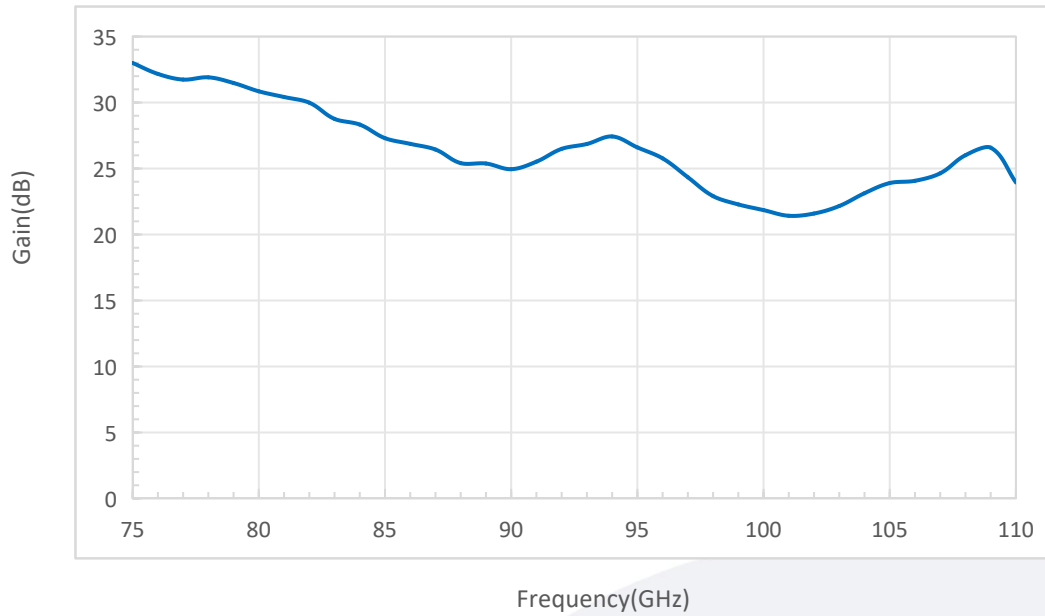

Psat vs Frequency

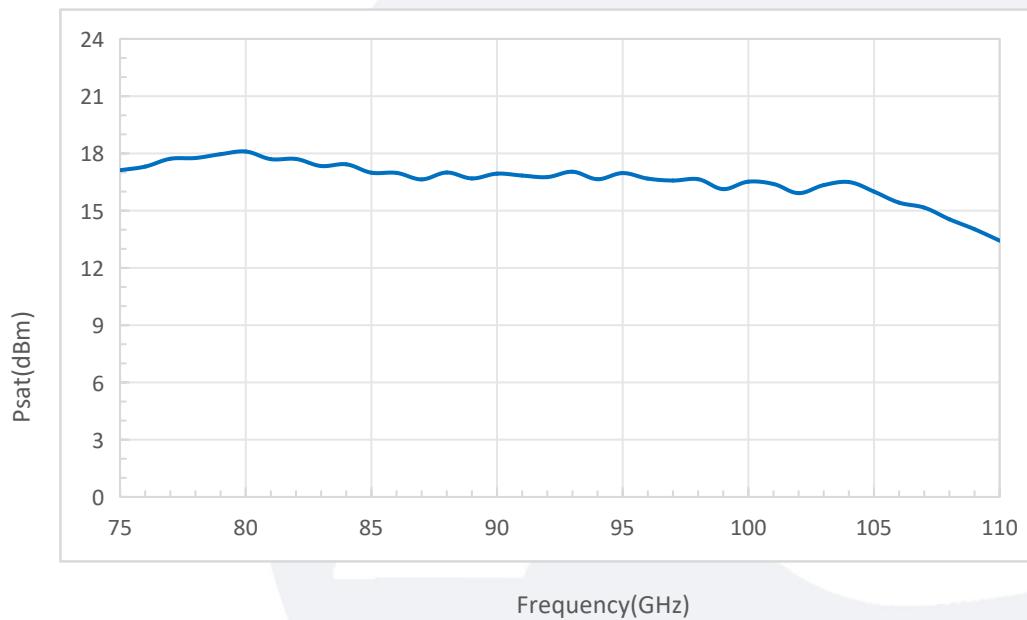

Note: Above data is for ref only, actual data may vary from unit to unit depending on operating environment and other factors like material lots etc.