

Part No.: RS2W100600-1.85

Power Divider/Combiner 2 Way 1.85 50Ω 10 to 60 GHz

电气特性 Electrical:

工作频率 Frequency Range: 10-60 GHz
 插入损耗 Insertion Loss: ≤4.2dB typ.
 (不包含理论)
 驻波 VSWR: ≤1.8 : 1
 隔离 Isolation: ≥15dB
 幅度平衡 Amplitude Balance: ≤±0.8dB
 相位平衡 Phase Balance: ≤±8°
 耐功率 Power Handling: 20 Watt
 方向功率 Reverse Power : 2 Watt
 阻抗 Impedance: 50 OHMS

机械特性 Mechanical :

温度范围 Temperature Range: -55° C - +85° C
 接口 Connectors: 1.85-Female
 相对湿度 Relative Humidity: 0 ~ 90%

外形尺寸 Outline Drawing:

Unit: mm

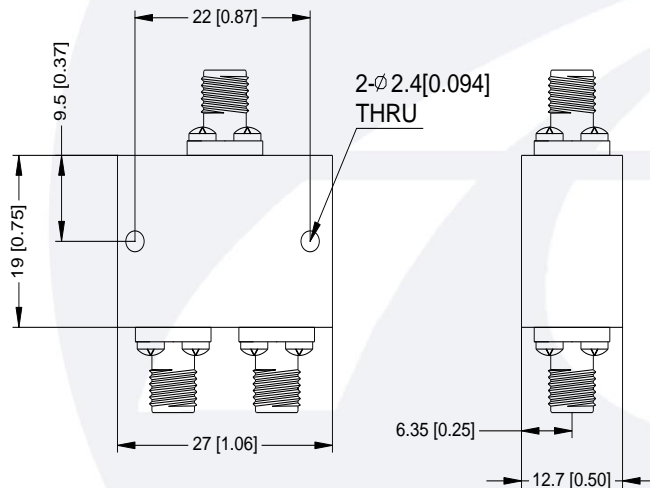

典型曲线 Typical Performance Date:

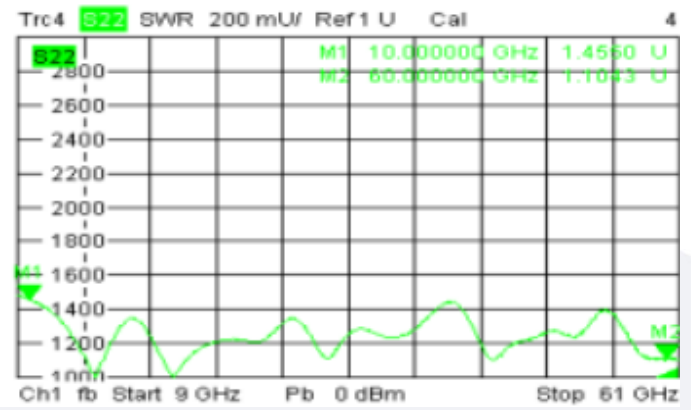
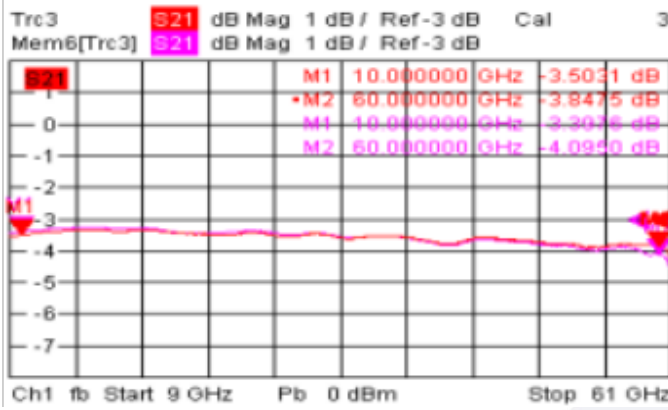
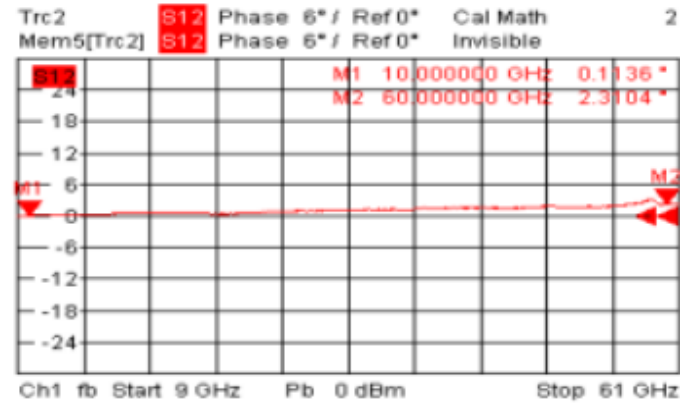
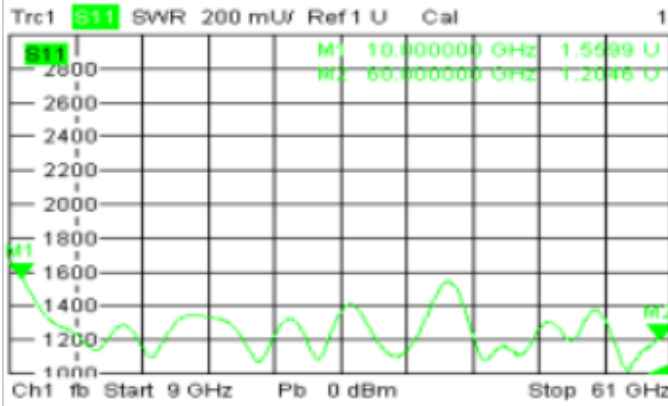

Trc2 **S12** dB Mag 2 dB / Ref -16 dB Cal

2 (Max)

