

## SPDT Coaxial Switches

R12-SF12T18-DI, Coaxial Switches, SPDT, SMA, Failsafe, 12VDC, TTL, DC to 18 GHz, DSUB-9, Electronic Type Indicator

R12-SF24T18-DI, Coaxial Switches, SPDT, SMA, Failsafe, 24VDC, TTL, DC to 18 GHz, DSUB-9, Electronic Type Indicator

R12-SF28T18-DI, Coaxial Switches, SPDT, SMA, Failsafe, 28VDC, TTL, DC to 18 GHz, DSUB-9, Electronic Type Indicator

### 电气参数 Electrical Characteristics:

参数Parameter	条件Condition
频率范围 Frequency range	DC-18GHz
阻抗 Impedance	50 Ω
开关模式 Operation mode	Failsafe
开关顺序 Switch sequence	Break before make
切换时间 Switching time	15 ms max
机械寿命 Mechanical life	5 million min
TTL input	0-0.8 V(OFF), 2.4-5 V(ON)
额定电压 Rated voltage	12 24 28 VDC
工作电流 Operating current at 23 °C	190 98 83 mA
指示灯额定值 Indicator rating	Electronic Type Indicator Max withstand voltage: 60VDC Max current capacity: 100mA Max "ON" resistance: 16Ω Note: VDC(i) and COM- must be connected to operate.



### 射频特性 RF Specifications:

频率范围 FREQUENCY RANGE(GHz)	DC-6	6-12	12-18
插入损耗 INSERTION LOSS (MAX) dB	0.2	0.25	0.4
隔离度 ISOLATION (MIN) dB	70	70	60
电压驻波比 V.S.W.R. (MAX)	1.2:1	1.3:1	1.4:1

### 环境和物理特性 Environmental And Physical Characteristics:

参数Parameter	条件 Condition
工作温度范围 Operating temperature range	-25°C to +65°C(Standard ) -55°C to +85°C(Optional)
振动 Sine vibration(Operating)	20-2000Hz , 10g
冲击 Shocks(Non Operating)	50g / 12ms, ½ sine
射频接口 RF Connector type	SMA Female
控制接口 Control connector	D-SUB 9 Pin Male
重量 Weight	70g Max

外形尺寸 **Outline Drawing:** Unit: mm

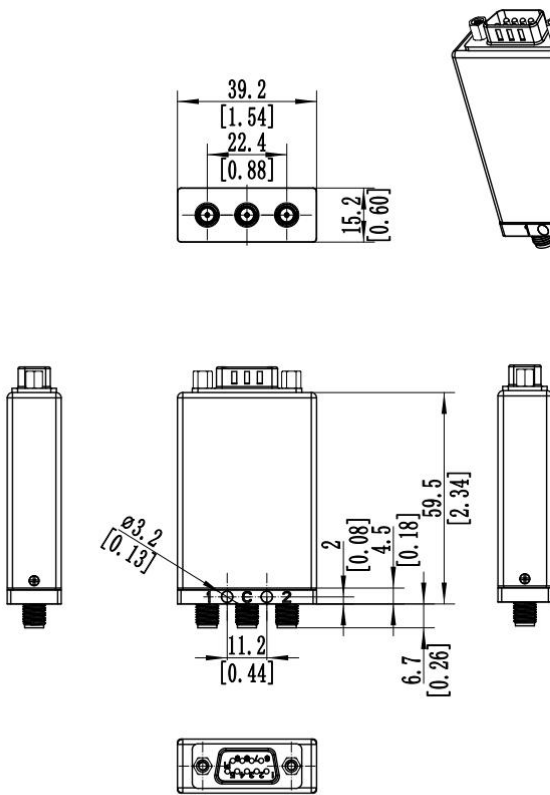

9 PIN 公头DSUB

原理图 **Schematic:**

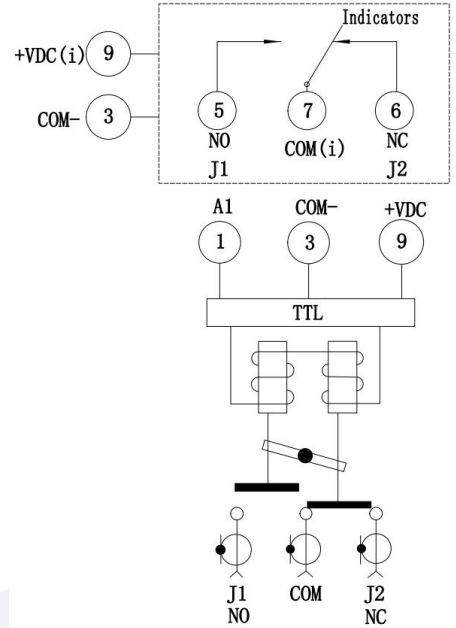

功率曲线图 **Average power:**

- This graph is based on the following conditions:
- Ambient temperature: + 25 °C
  - Sea level
  - V.S.W.R.: 1 and cold switching

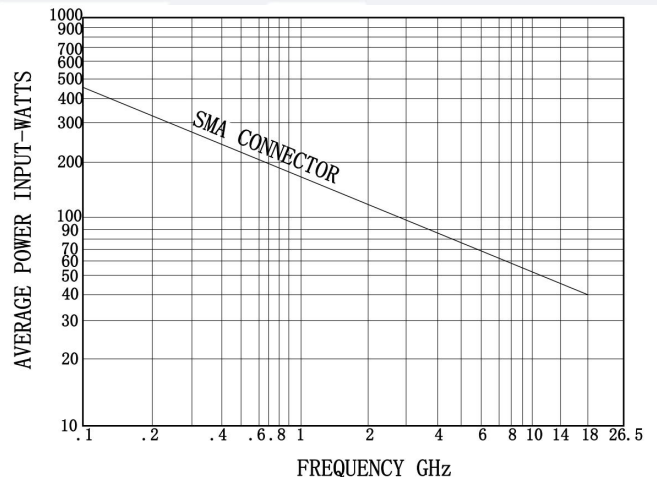

针脚定义 **Pin Definition:**

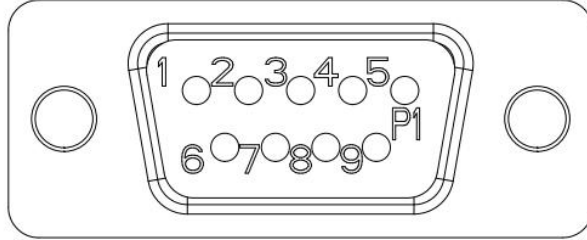

9 PIN D-SUB		RF Connect Used
Pin NO.	Function	SPDT
1	A1 (TTL IN)	NO:J1-COM
	0	NC:J2-COM
2	UNUSED	
3	COM-	
4	UNUSED	
5	IND.1	NO:J1-COM
6	IND.2	NC:J2-COM
7	COMi(IND.)(V+)	
8	UNUSED	
9	+VDC/VDC(i)	

标准型号 **Part Number:**

标准型号 Part Number	额定电压 Rated Voltage	可选项 Option
SPDT		
R12-SF12T18-DI	12VDC	-S
R12-SF24T18-DI	24VDC	例如:R12-SF12T18-DIS
R12-SF28T18-DI	28VDC	(备注, S型号满足IP65)

**典型曲线 Typical Performance Data:**

