

Model:TMAM-055090-0612-12
**E-Band Active Multiplier
 X6, 55-90 GHz, +12 dBm Output Power**
Feature:

- Output Frequency:55-90 GHz
- Output Power : 12dBm Typ
- Low power consumption

电气特性 Electrical Specifications:

参数Parameter	Min	Typ	Max	单位Units
输出频率 Output Frequency	55		90	GHz
输出功率 Output Power		12		dBm
输入频率 Input Frequency	9.16		15	GHz
输入功率 Input Power	3	5	7	dBm
谐波抑制 Harmonics		25		dBc
倍频次数 Multiply Factor		6		
供电电压 DC Voltage		12		V
供电电流 DC Supply Current		100		mA

机械特性 Mechanical Specifications:

参数 Parameter	指标 Value	单位 Units
输出接口Output Connector	WR-12/UG-387/U	
输入接口Input Connector	SMA Female	
直流偏置 Bias	Solder Pin	
尺寸 Size	58*38*22	mm

绝对最大值 Absolute Maximum Ratings:

参数 Parameter	指标 Value
供电偏置电压 Supply Bias Voltage	12 V
输入功率 RF Input Power	+10 dBm
ESD灵敏度 ESD sensitivity (HBm)	Class 0, passed 150V

外形尺寸 Outline Drawing:

Unit: mm

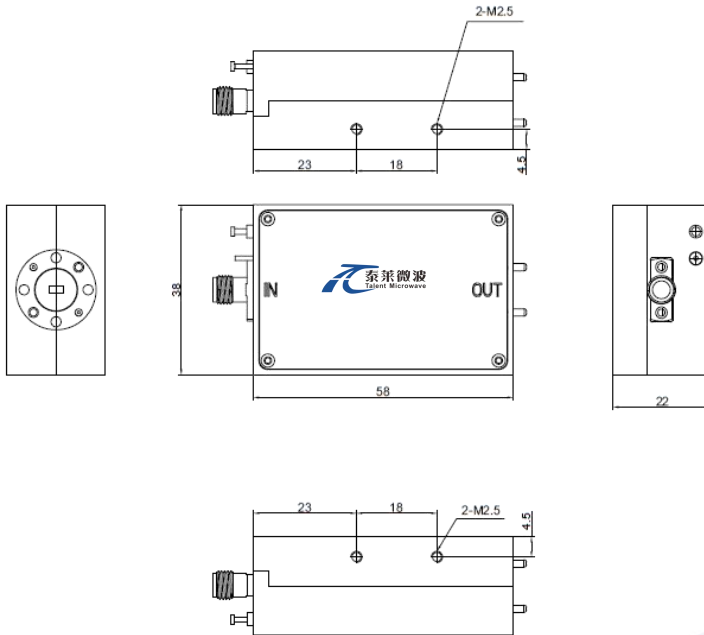

OBSERVE PRECAUTIONS
ELECTROSTATIC SENSITIVE
DEVICES

温度环境 Environmental Conditions:

参数 Parameter	Min	Typ	Max	单位 Units
操作温度 Operating Temperature	-10		+65	°C
存储温度 Non-operating Temperature	-25		+75	°C
相对湿度 Relative humidity		95		%
海拔 Altitude		50,000		feet
震动 Shock / Vibration(MIL-STD-810F)	25g rms (15 degree 2KHz) endurance, 1 hour per axis			
冲击 Shock(non operating)	20G for 11msc half sin wave,3 axis both directions			

订货信息 Ordering Information:

标准型号 Part Number	描述 Description	版本号 Revision
TMAM-055090-0612-12	Active Multiplier,X6,55-90GHz, Output Power:12dBm,WR-12/UG-387/U,SMA Female	Rev.1.1

典型曲线 Typical Performance Data:

Output Power vs Frequency

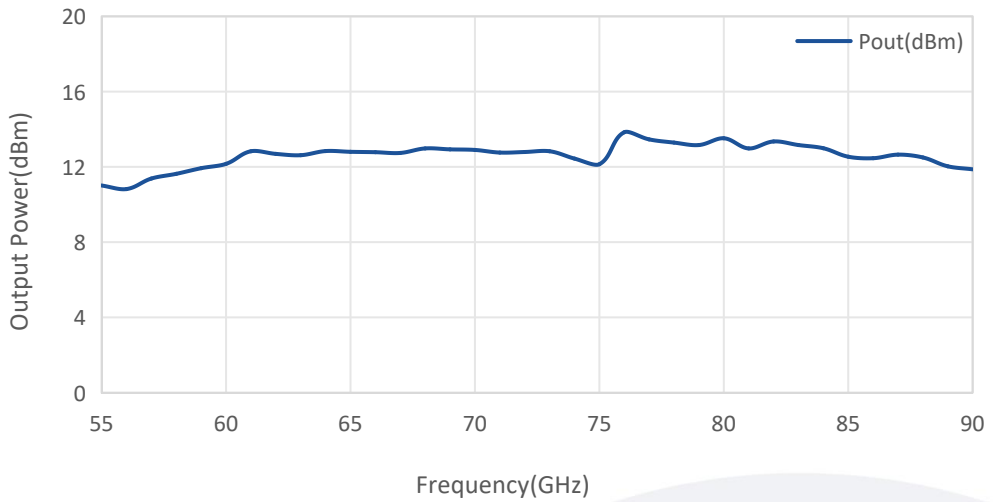

Harmonic Suppression vs Frequency

