

Model: TMPA-075110-1820-10
Power Amplifier
75-110 GHz, Gain:18 dB, Psat:20 dBm
Feature:

- Frequency Range:75-110 GHz
- Gain:18 dB Typ
- Output Power Psat:20 dBm Typ
- Good Power and Gain Flatness

电气特性 Electrical Specifications:

参数Parameter	Min	Typ	Max	单位Units
频率范围 Frequency range	75-110			GHz
增益 Gain		18		dB
饱和输出功率 Output Psat	17	20		dBm
输入驻波 Input VSWR		3		:1
输出驻波 Output VSWR		3		:1
直流电压 DC Voltage		12		V DC
直流电流 DC Supply Current		350		mA

机械特性 Mechanical Specifications:

参数Parameter	指标 Value	单位Units
输入输出接口 Input /Output Connector	WR-10/UG-387/U	
直流偏置 DC Bias	Solder Pin	
尺寸 Size	/	mm
重量 Weight	/	g

绝对最大值 Absolute Maximum Ratings:

参数Parameter	指标 Value
供电偏置电压 Supply Bias Voltage	TBD
输入功率 RF Input Power	10dBm
ESD灵敏度 ESD sensitivity (HBm)	Class 0, passed 150V

 Available 220V System
 Benchtop Amplifier

外形尺寸 Outline Drawing:

Unit: mm(Inches)

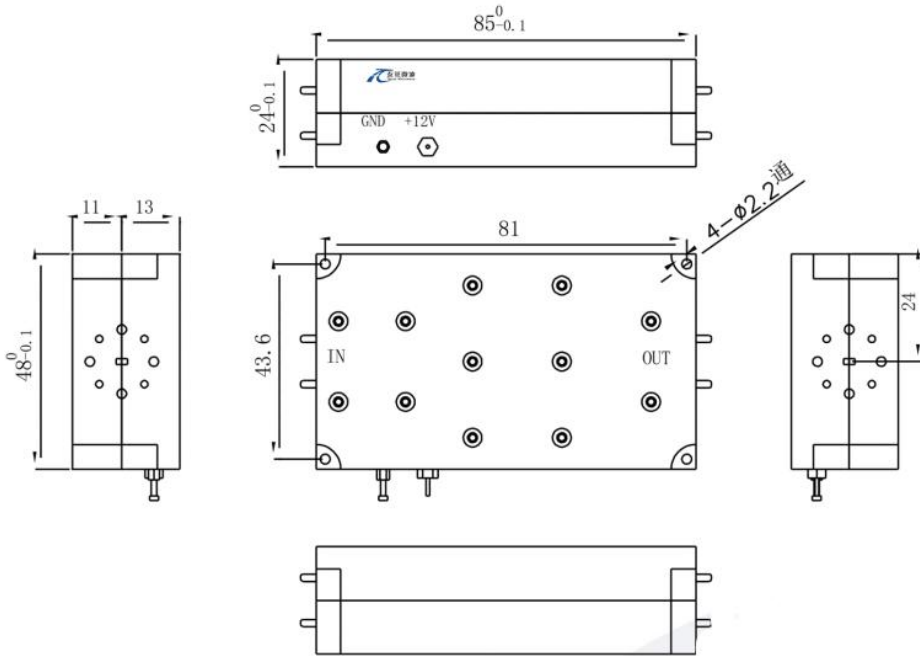

温度环境 Environmental Conditions:



OBSERVE PRECAUTIONS
ELECTROSTATIC SENSITIVE
DEVICES

参数 Parameter	Min	Typ	Max	单位 Units
操作温度 Operating Temperature	0		+50	°C
存储温度 Non-operating Temperature	-55		+125	°C
相对湿度 Relative humidity		95		%
海拔 Altitude	50,000			feet
震动 Shock / Vibration(MIL-STD-810F)	25g rms (15 degree 2KHz) endurance, 1 hour per axis			
冲击 Shock(non operating)	20G for 11msc half sin wave,3 axis both directions			

订货信息 Ordering Information:

标准型号 Part Number	描述 Description	版本号 Revision
TMPA-075110-1820-10	Power Amplifier,75-110 GHz, Gain:18 dB Typ,Psat:20 dBm Typ,12V DC,WR-10	Rev.1.1

典型曲线 Typical Performance Data:

Gain vs Frequency

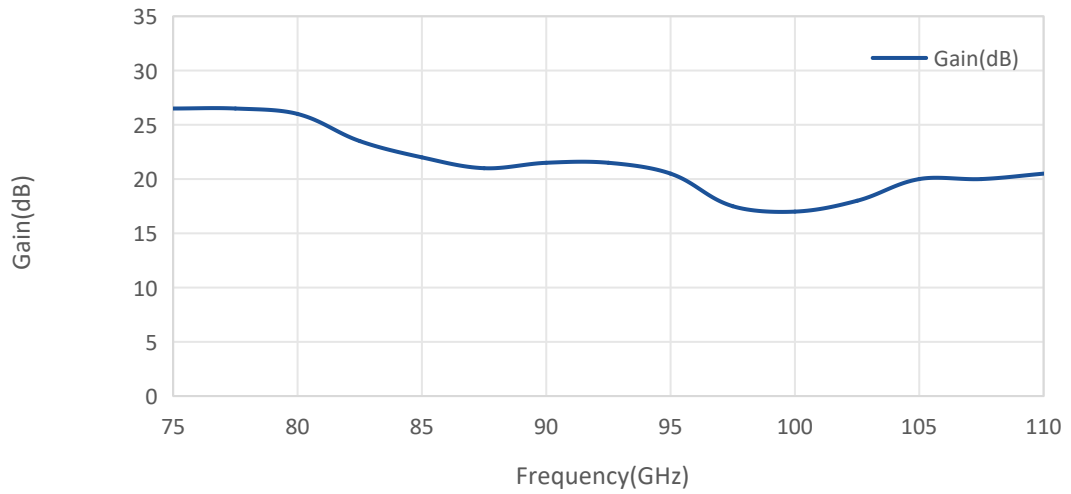

VSWR vs Frequency

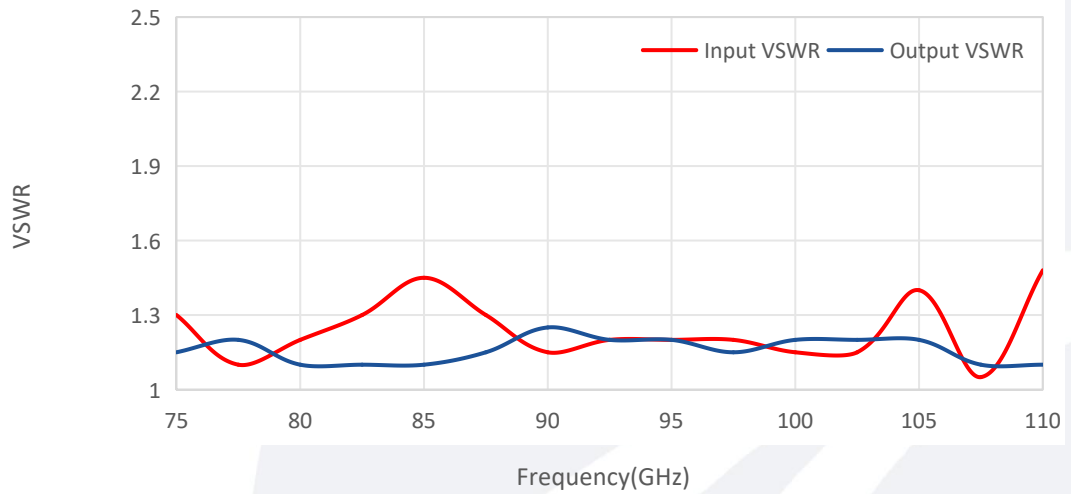

Psat vs Frequency

