

Model: TLLA1G18G-50-30
Low Noise Amplifier
1-18GHz, NF:2.0 dB, Gain:50dB, P1dB:10dBm
Feature:

- Ultra Wide Band: 1-18GHz
- Gain: 50 dB
- Noise Figure: 2.0dB Typ
- Unconditional stability
- 50 Ohm Matched Input / Output

电气特性 Electrical:

参数Parameter	Min.	Typ.	Max.	单位Units
频率范围 Frequency range	1-18			GHz
增益 Gain		50		dB
增益平坦度 Gain Flatness		±2		dB
噪声系数 Noise Figure		2.0	3.0	dB
线性输出功率P1dB		+15		dBm
输入驻波 Input VSWR		1.7		: 1
输出驻波 Output VSWR		1.7		: 1
直流电压 DC Voltage	+8	+12	+15	V DC
直流供电 DC power supply		90		mA
阻抗 Impedance	50			Ohms

机械特性 Mechanical :

参数Parameter	指标 Value
输入输出接口 Input /Output Connector	SMA Female
直流偏置 Bias	Solder Pin
尺寸 Size	44.8mm*29.2mm*11mm
重量 Weight	35 g



 Available 220V System
 Benchtop Amplifier

绝对最大值 Absolute Maximum Ratings:

参数Parameter	指标 Value
供电偏置电压 Supply Bias Voltage	+15 V
输入功率 RF INPUT POWER	+15 dBm
ESD灵敏度 ESD sensitivity (HBm)	Class 0, passed 150V

外形尺寸 Outline Drawing:

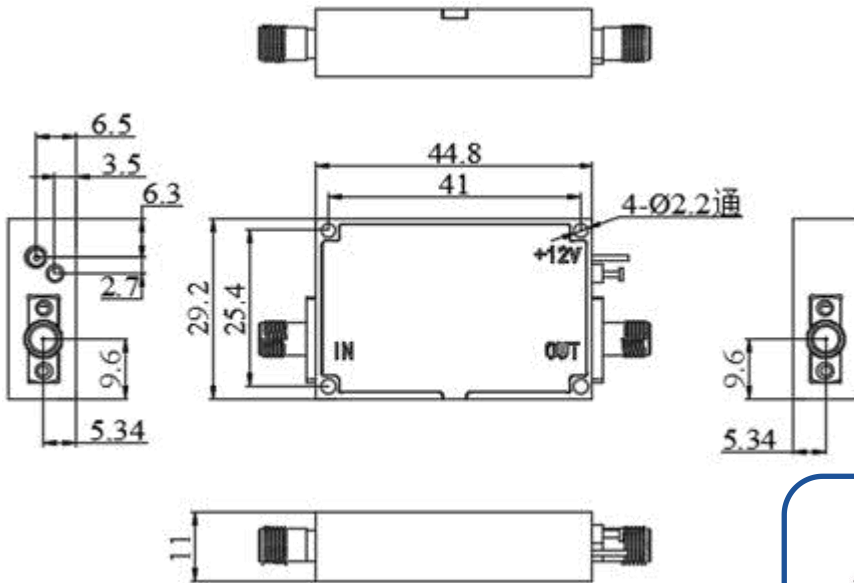
Unit: mm



OBSERVE PRECAUTIONS
ELECTROSTATIC SENSITIVE
DEVICES

*****Heat Sink Required During Operation**

温度环境 Environmental Conditions:

参数Parameter	Min.	Typ.	Max.	单位Units
操作温度 Operating Temperature	-40		+85	°C
存储温度 Non-operating Temperature	-55		+125	°C
相对湿度 Relative humidity	95			
海拔 Altitude	10000		30000	feet
震动 Shock / Vibration(MIL-STD-810F)	25g rms (15 degree 2KHz) endurance, 1 hour per axis			
冲击 Shock(non operating)	20G for 11msc half sin wave,3 axis both directions			

订货信息 Ordering Information:

标准型号 Part Number	描述 Description	版本号Revision
TLLA1G18G-50-30	Low Noise Amplifier, 1-18GHz, Noise Figure:2.0 dB, Gain:50 dB,P1dB:15dBm,+12~15V DC,Without Heatsink	Rev.1.1
TLLA1G18G-50-30-HS	Low Noise Amplifier, 1-18GHz, Noise Figure:2.0 dB, Gain:50 dB,P1dB:15dBm,+12~15VDC,With Heatsink	Rev.1.1

典型曲线 Typical Performance Data:

Gain vs Frequency

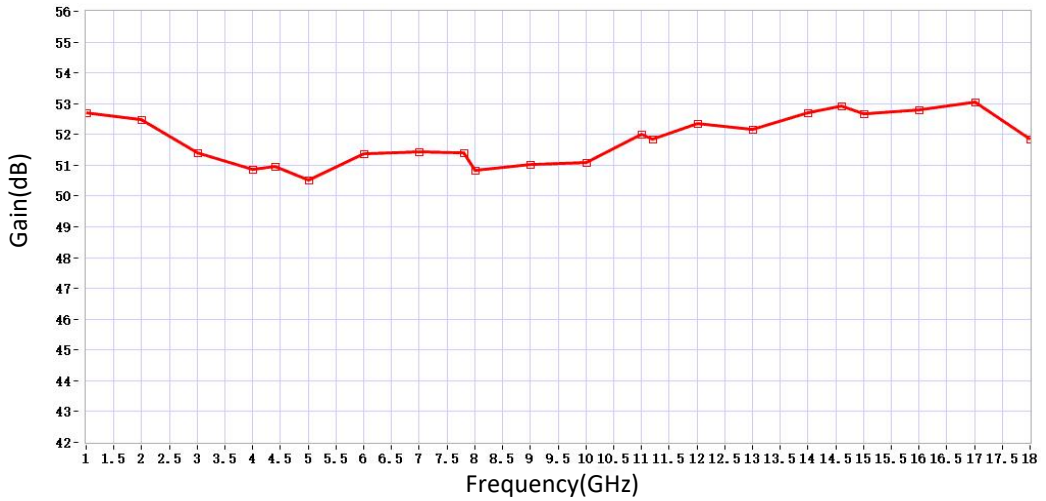

Gain vs Output Power

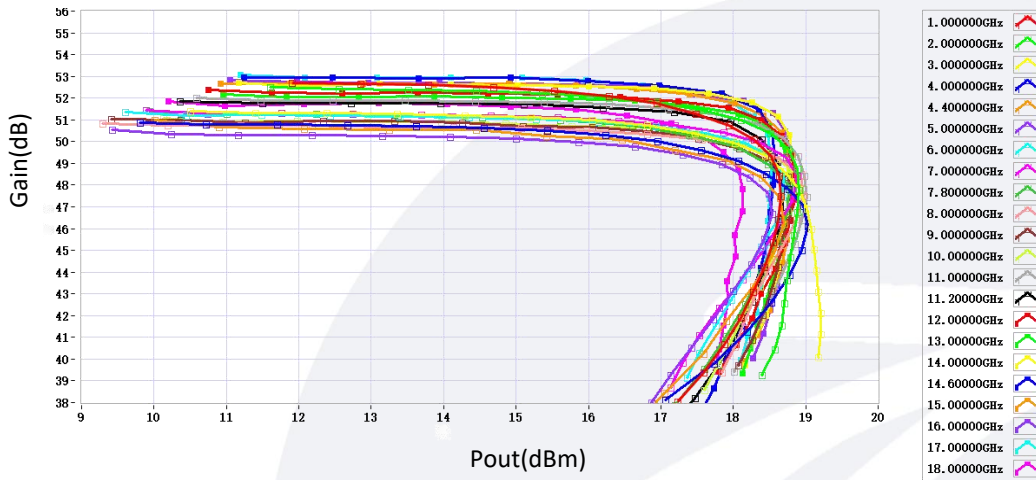

Noise Figure VS Frequency

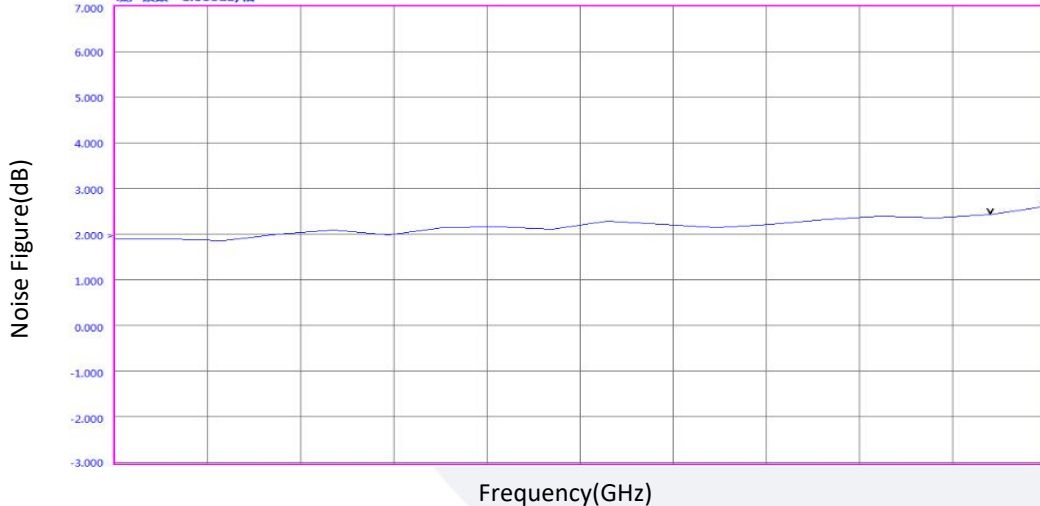

典型曲线 Typical Performance Data:

P1dB vs Frequency

