

Model: TLHM-110170-0215-06
Harmonic Mixer, D-Band
RF:110-170 GHz, LO:55-85GHz, IF:DC-15GHz
Feature:

- Low LO Power Requirement
- Subharmonic Mixing
- Compact Package

电气特性 Electrical:

参数Parameter	Min.	Typ.	Max.	单位Units
RF频率 RF Frequency	110		170	GHz
LO频率 LO Frequency	55	85		GHz
IF频率 IF Frequency	DC		15	GHz
LO 驱动功率 LO-Input power	6	8	10	dBm
输入端口驻波 RF VSWR			3.0	:1
单边带变频损耗 SSB Conversion Loss		12		dB

* Conversion Loss degrade below 120GHz

机械特性 Mechanical :

参数Parameter	指标 Value	单位Units
RF 接口RF Connector	WR-06/UG-387	
LO接口LO Connector	WR-12/UG-387	
IF接口 IF Connector	SMA Female	
尺寸 Size	28*25*20(不含接头)	mm
重量 Weight	200	g

绝对最大值 Absolute Maximum Ratings:

参数Parameter	指标 Value
RF 功率 RF Input Power	TBD
LO 功率 LO Input Power	10 dBm
ESD灵敏度 ESD sensitivity (HBm)	Class 0, passed 150V

外形尺寸 Outline Drawing:

Unit: mm(Inches)

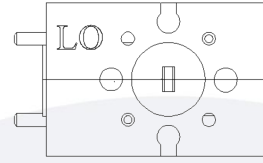
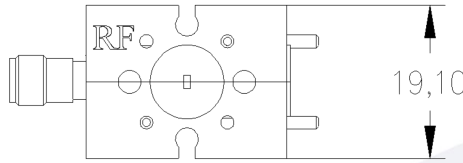
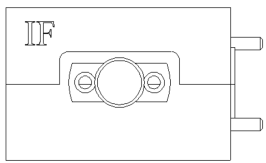
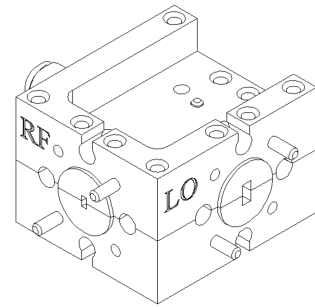
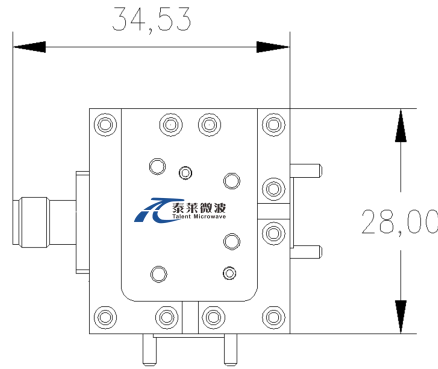

OBSERVE PRECAUTIONS
ELECTROSTATIC SENSITIVE
DEVICES

温度环境 Environmental Conditions:

参数Parameter	Min.	Typ.	Max.	单位Units
操作温度 Operating Temperature	0		+40	°C
存储温度 Non-operating Temperature	-25		+65	°C
相对湿度 Relative humidity		95		%
海拔 Altitude	50,000			feet
震动 Shock / Vibration(MIL-STD-810F)	25g rms (15 degree 2KHz) endurance, 1 hour per axis			
冲击 Shock(non operating)	20G for 11msc half sin wave,3 axis both directions			

订货信息 Ordering Information:

标准型号 Part Number	描述 Description	版本号Revision
TLHM-110170-0215-06	Harmonically Mixer, D-Band RF:110-170GHz, LO:55-85GHz, IF:DC-15GHz	Rev.1.1

典型曲线 Typical Performance Data:

Conversion Loss vs RF Frequency

IF Frequency=0.1GHz

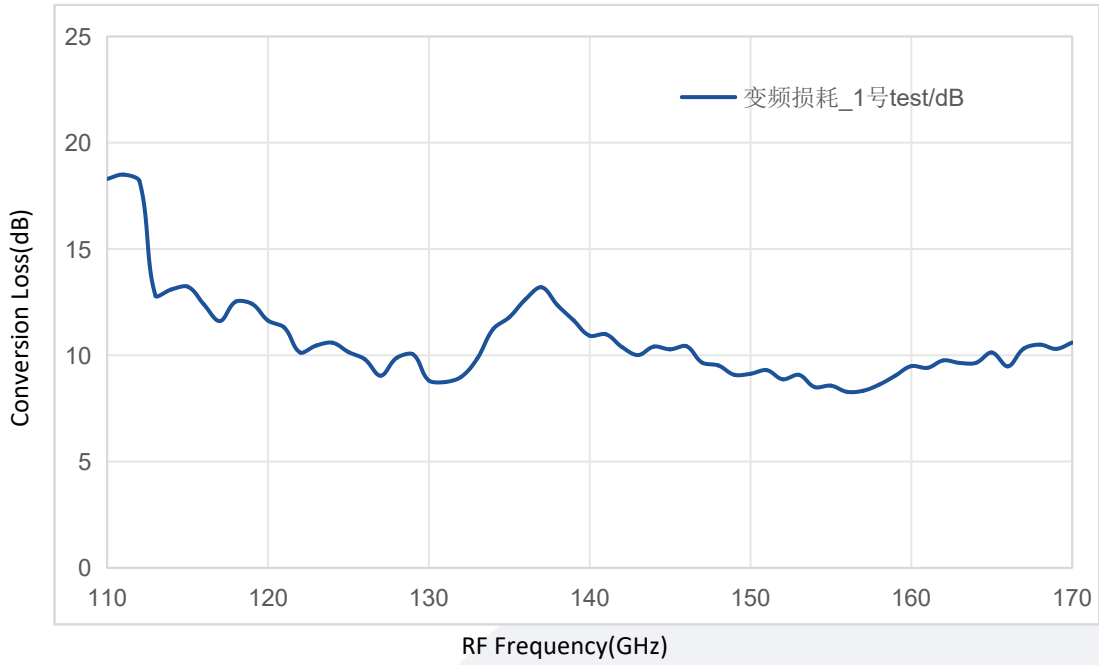

Conversion Loss vs IF Frequency

