

Model: TLPA0.5M5M-53-53-BC
**Solid State High Power Amplifier Systems
 0.5-5MHz, Gain: 53dB, Psat: 53dBm, 220V AC**
Feature:

- Ultra Wide Band: 0.5-5MHz
- Gain: 53dB Min
- Psat Output Power: 53 dBm Min
- Good Power and Gain Flatness
- 50 Ohm Matched Input / Output

电气特性 Electrical:

参数Parameter	Min.	Typ.	Max.	单位Units
频率范围 Frequency range	0.1-5			MHz
增益 Gain	53	55		dB
增益平坦度 Gain Flatness		±1.0	±1.5	dB
线性输出功率P1dB		48		dBm
饱和输出功率Psat	53	54		dBm
杂散			-60	dBc
谐波			-10	dBc
增益调节范围		30		dB
输入驻波 Input VSWR		1.5	2.0	:1
输出驻波 Onput VSWR				:1
交流电压 AC Voltage	110	220		V AC
直流电流 DC Supply Current	5A@220V AC			A
阻抗 Impedance	50			Ohms

机械特性 Mechanical :

参数Parameter	指标 Value	单位Units
输入输出接口 Input /Output Connector	N Female	
尺寸 Size	3U*500mm深度	
重量 Weight	17	kg

绝对最大值 Absolute Maximum Ratings:

参数Parameter	指标 Value
输入功率 RF INPUT POWER	5 dBm
ESD灵敏度 ESD sensitivity (HBm)	Class 0, passed 150V

外形尺寸 Outline Drawing:

Unit: mm

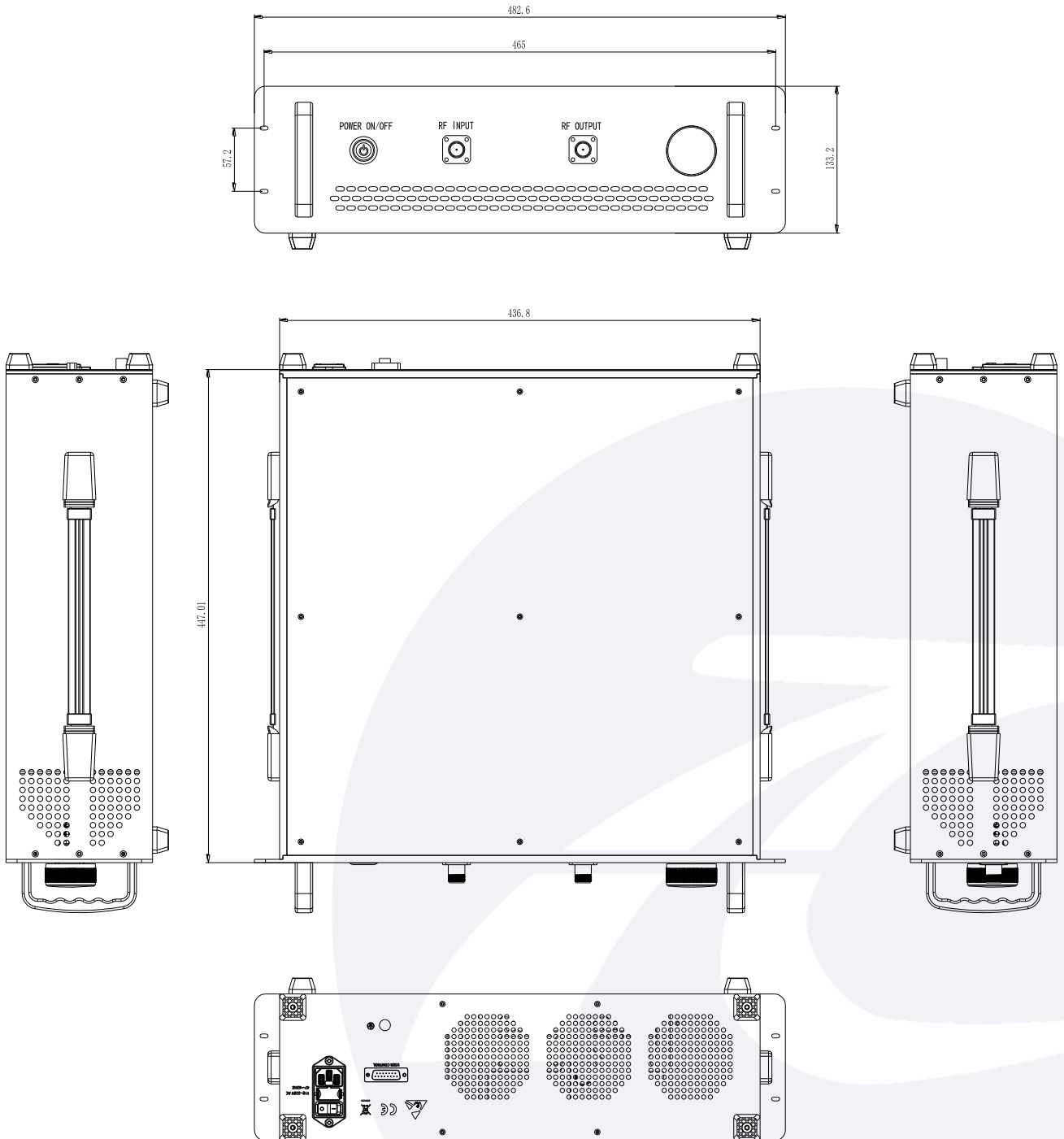

外形尺寸 Outline Drawing:

Unit: mm

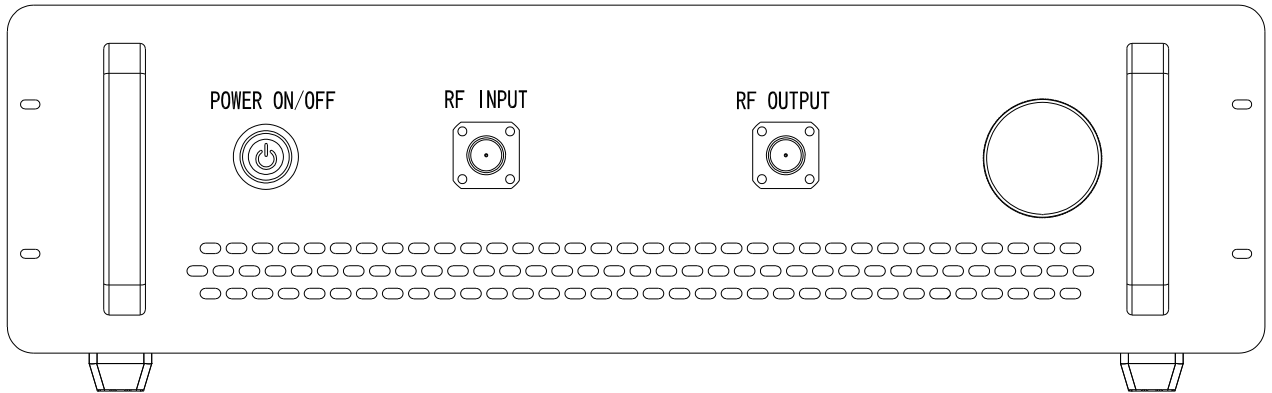

温度环境 Environmental Conditions:

参数Parameter	Min.	Typ.	Max.	单位Units
操作温度 Operating Temperature	-45		+50	°C
存储温度 Non-operating Temperature	-55		+125	°C
相对湿度 Relative humidity		95		%
海拔 Altitude		30,000		feet
震动 Shock / Vibration(MIL-STD-810F)	25g rms (15 degree 2KHz) endurance, 1 hour per axis			
冲击 Shock(non operating)	20G for 11msc half sin wave,3 axis both directions			

订货信息 Ordering Information:

标准型号 Part Number	描述 Description	版本号Revision
TLPA0.5M5M-53-53-BC	Power amplifier 0.5-5MHz,Gain:53dB,Psat:53dBm,220V AC,Built in Fan Cooling	Rev.1.0