

Coaxial Band-pass Filter

3.65-3.95 GHz/SMA Female/SMA Male

Model: TLBF-3G8-300M-E

TLBF-3G8-300M-E is a coaxial band-pass filter with a passband frequency from 3.65 to 3.95 GHz and a rejection frequencies @ ≤ 2.65 GHz and ≥ 4.95 GHz. The maximum insertion loss of the filter is 1.2 dB and the typical rejection is 70 dB.

Features:

- Passband Frequency Range 3.65 to 3.95 GHz
- Low Insertion Loss
- High Rejection
- Steep Rejection Skirts
- Field Replaceable RF Connectors

Applications:

- Instrumentations
- Radar Systems
- System Integrations

电气特性 Electrical Characteristics:

参数 Parameter	Min	Typ	Max	单位 Units
通带频率范围 Passband Frequency range	3.65		3.95	GHz
带宽 Band Width			0.3	GHz
通带插损 Passband Insertion Loss			1.2	dB
带内波动 Pass Band Ripple		0.4		dB
群时延 Group Delay Flatness		1.3		NS
带外抑制 Rejection		>70dB@fo \pm 1GHz		dB
耐受功率 Power Handling			15	W
驻波 VSWR			1.3	:1
阻抗 Impedance		50		Ohms

环境和机械特性 Environmental And Physical Characteristics:

类型 Description	参数 Parameter	单位 Units
操作温度 Operating Temperature	-40 To +70	°C
接口 Connectors	SMA Female/SMA Male	
重量 Weight	/	g

外形图 Outline Drawing:

Unit:mm; Tolerance \pm 0.1mm

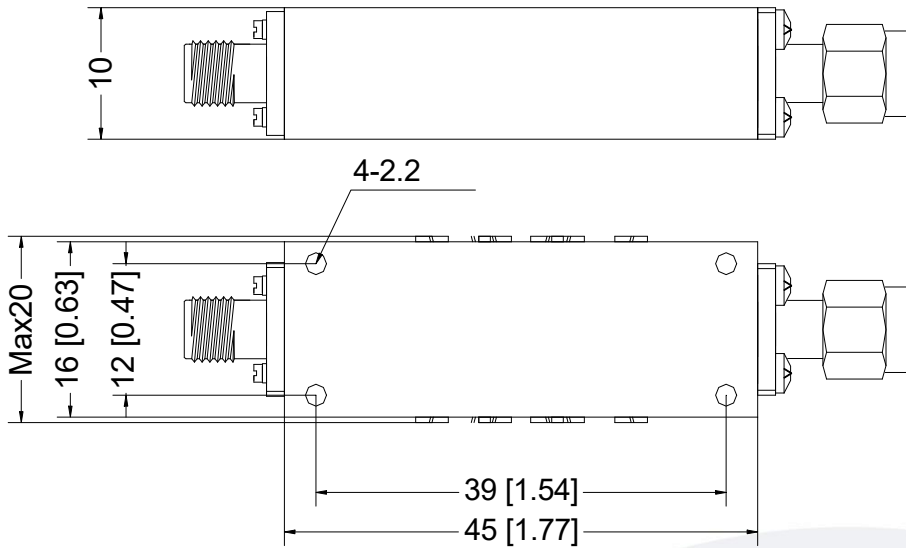

ESD Protection: Strictly adhere to ESD precautions to prevent electrostatic damage.

订货信息 Ordering Information:

标准型号 Base Number	描述 Description	版本号 Revision
TLBF-3G8-300M-E	Coaxial Band-pass Filter, Passband frequency range: 3.65-3.95GHz, Passband Insertion Loss: 1.2dB, SMA Female/SMA Male	Rev.1.0

典型曲线 Typical Performance Data:

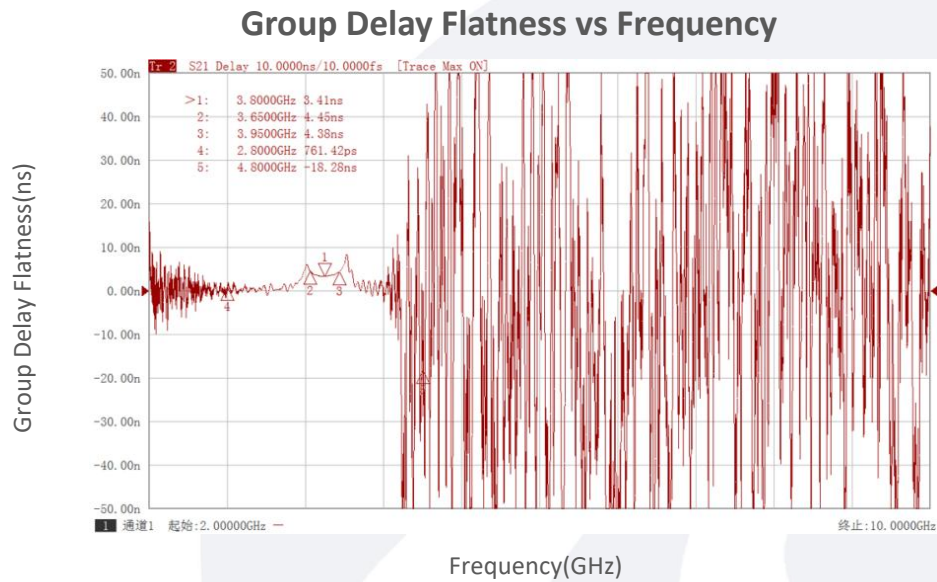
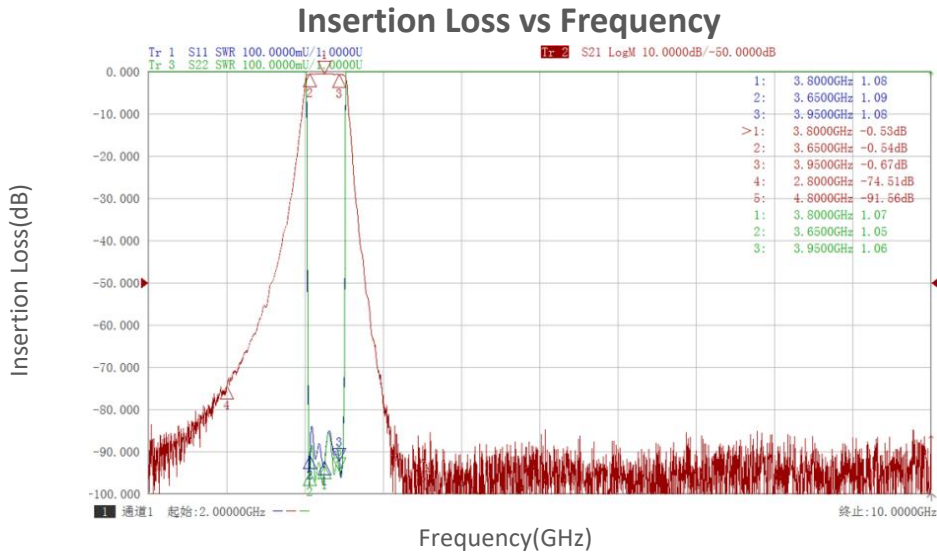

Note: Above data is for ref only, actual data may vary from unit to unit depending on operating environment and other factors like material lots etc.