

Standard Gain Horn Antenna

WR-12/60-90GHz/15 dBi Typ, Gain

Model:TL-12SHA15

TL-12SHA15 is a standard gain horn antenna that operates from 60 GHz to 90 GHz. The antenna offers 15 dBi nominal gain. The input of this antenna is a WR-12 waveguide with UG-387/U-M anti-cocking flange. The standard gain horn is offered for antenna range calibration purpose mainly, but it can be also used for general purpose system set ups.

Features:

- Operating Frequency 60 to 90 GHz
- Gain: 15dBi Typ
- Linear Polarization
- Good Impedance Match

Applications:

- Antenna Ranges
- Antenna Gain Measurements
- System Setups

电气特性 Electrical Characteristics:

参数 Parameter	Min	Typ	Max	单位 Units
频率范围 Frequency Range	60		90	GHz
增益 Gain		15		dBi
极化方式 Polarization mode	Linear			
驻波 Input VSWR			1.5	:1

环境和机械特性 Environmental And Physical Characteristics:

类型 Description	参数 Parameter	单位 Units
材质 Material	Copper	
接口 Connectors	WR-12/UG-387/U	
尺寸 Size	19.1*19.1*10.5	mm

外形图 Outline Drawing:

Unit:mm

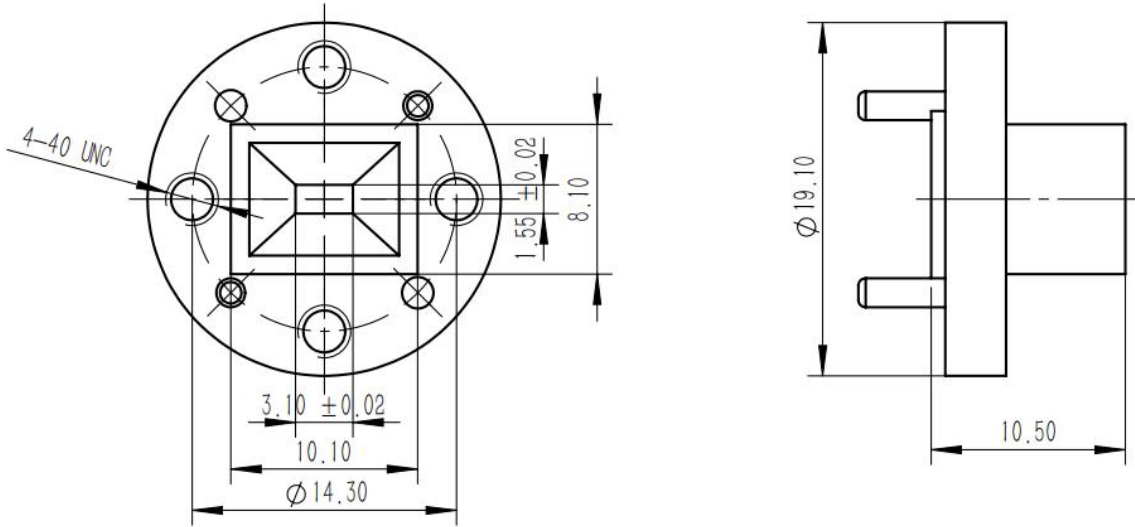

ESD Protection: Strictly adhere to ESD precautions to prevent electrostatic damage.

订货信息 Ordering Information:

标准型号 Base Number	描述 Description	版本号 Revision
TL-12SHA15	Standard Gain Horn Antenna, 60-90GHz, Gain: 15dBi Typ.	Rev.1.0