

## Standard Gain Horn Antenna

### WR-6.5/110-170GHz/25dBi Typ, Gain

Model:TL-6SHA25

TL-6SHA25 is a standard gain horn antenna that operates from 110 GHz to 170 GHz. The antenna offers 25 dBi nominal gain. The input of this antenna is a WR-6.5 waveguide with UG-387/U-M anti-cocking flange. The standard gain horn is offered for antenna range calibration purpose mainly, but it can be also used for general purpose system set ups.

#### Features:

- Operating Frequency 110 to 170 GHz
- Gain: 25dBi Typ
- Linear Polarization
- Good Impedance Match

#### Applications:

- Antenna Ranges
- Antenna Gain Measurements
- System Setups

### 电气特性 Electrical Characteristics:

参数 Parameter	Min	Typ	Max	单位 Units
频率范围 Frequency Range	110		170	GHz
增益 Gain		25		dBi
极化方式 Polarization mode	Linear			
驻波 Input VSWR			1.15	:1

### 环境和机械特性 Environmental And Physical Characteristics:

类型 Description	参数 Parameter	单位 Units
材质 Material	Brass	
接口 Connectors	WR-6.5/UG-387/U	
尺寸 Size	ø19.1*24.6	mm
重量 Weight	15	g

外形图 Outline Drawing:

Unit:mm

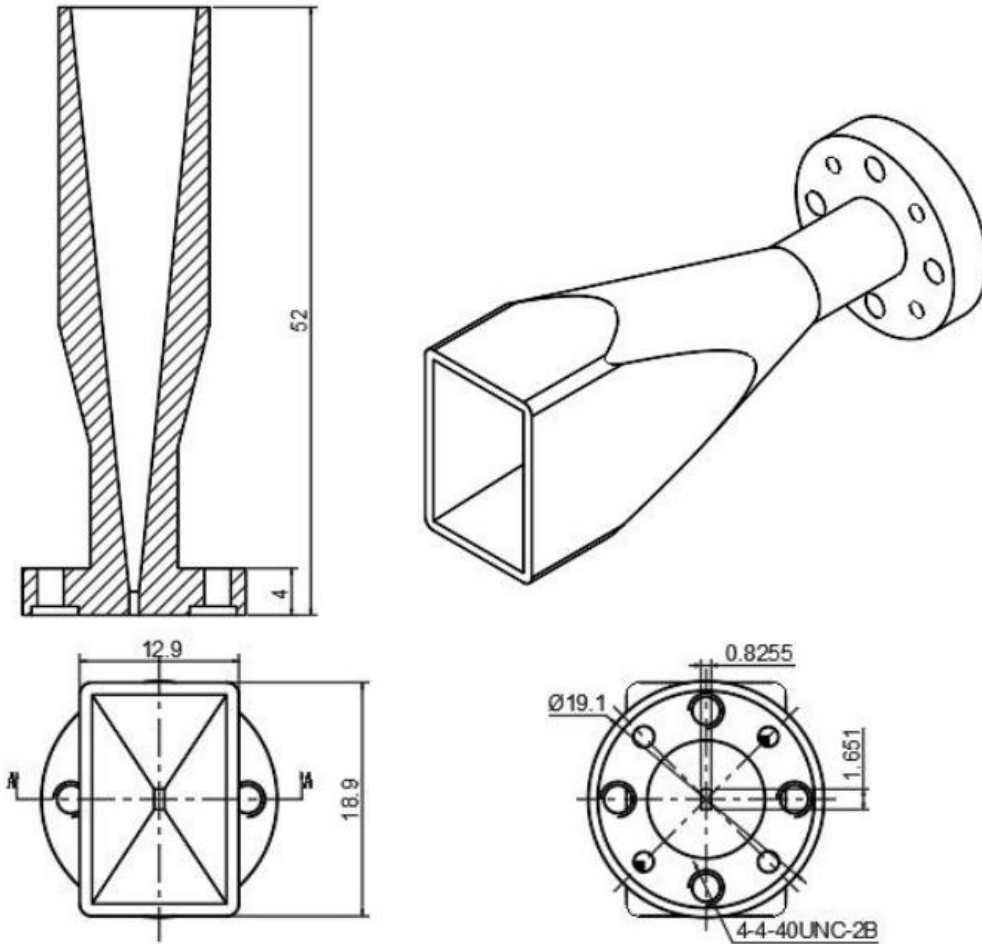

ESD Protection: Strictly adhere to ESD precautions to prevent electrostatic damage.

订货信息 Ordering Information:

标准型号 Base Number	描述 Description	版本号 Revision
TL-6SHA25	Standard Gain Horn Antenna, 110-170GHz, Gain: 25dBi Typ.	Rev.1.0

**典型曲线 Typical Performance Data:**

**Gain vs Frequency**

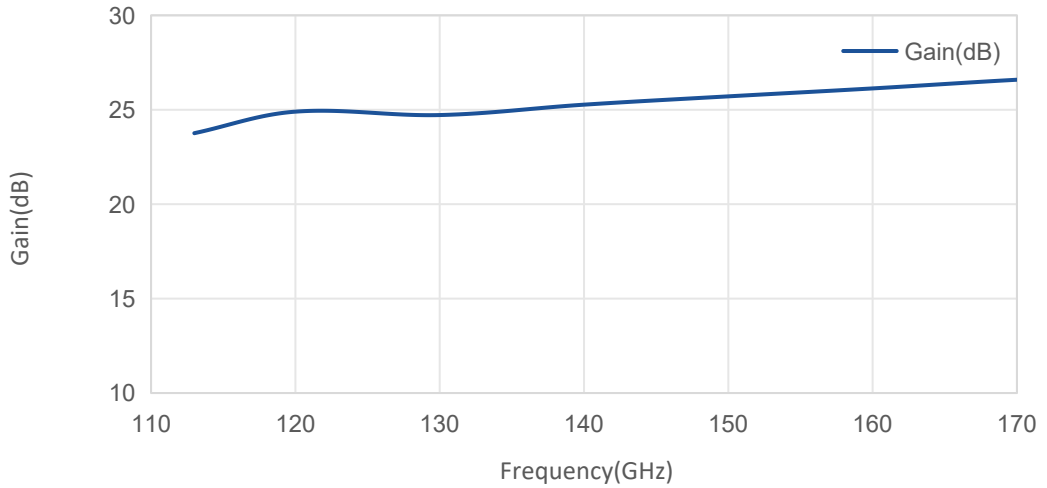

**110GHz:**

**Gain vs Theta**

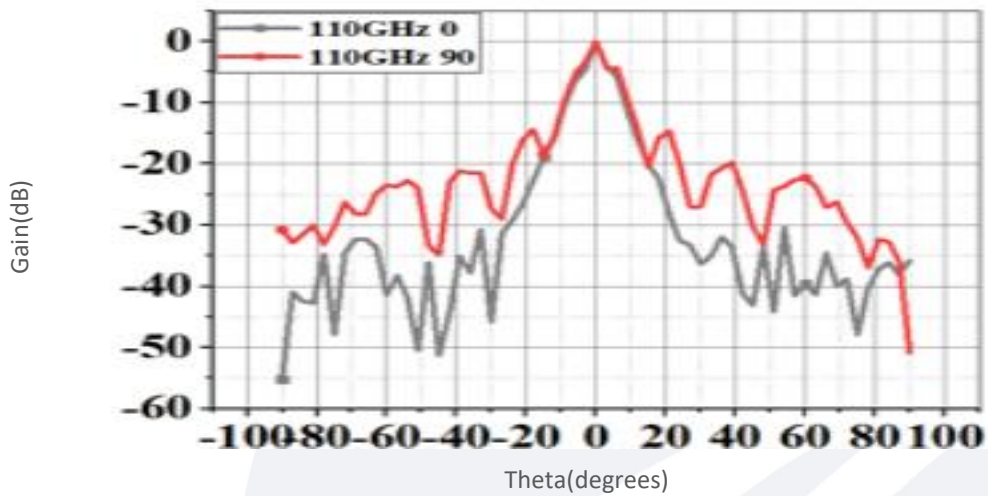

**120GHz:**

**Gain vs Theta**

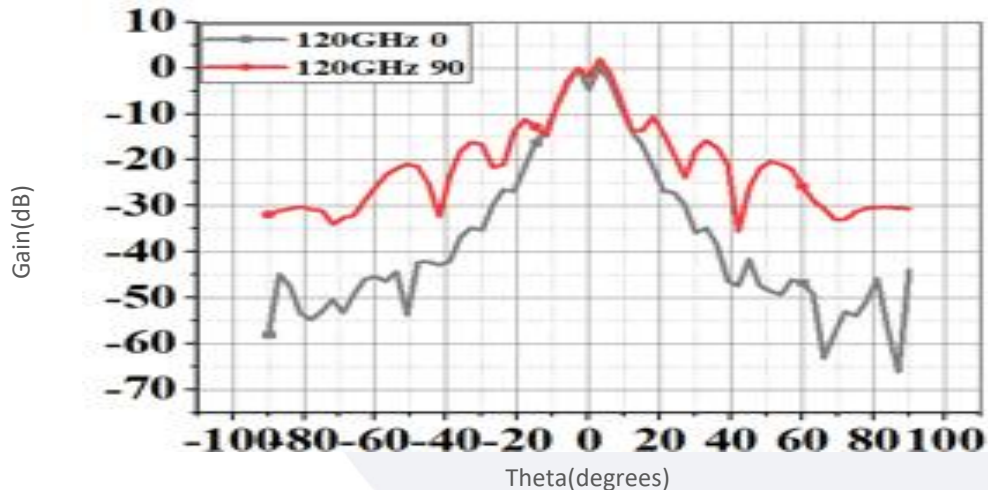

Note: Above data is for ref only, actual data may vary from unit to unit depending on operating environment and other factors like material lots etc.

**典型曲线 Typical Performance Data:**

130GHz:

**Gain vs Theta**

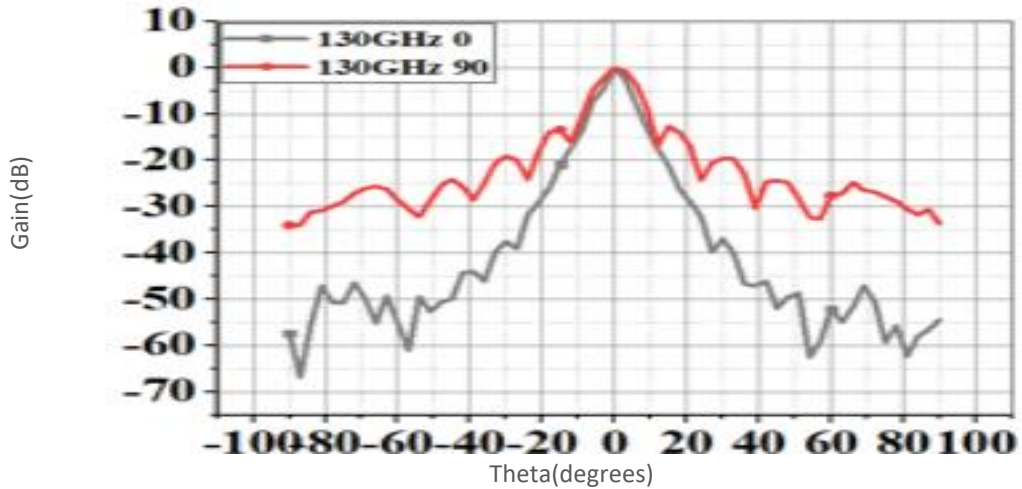

140GHz:

**Gain vs Theta**

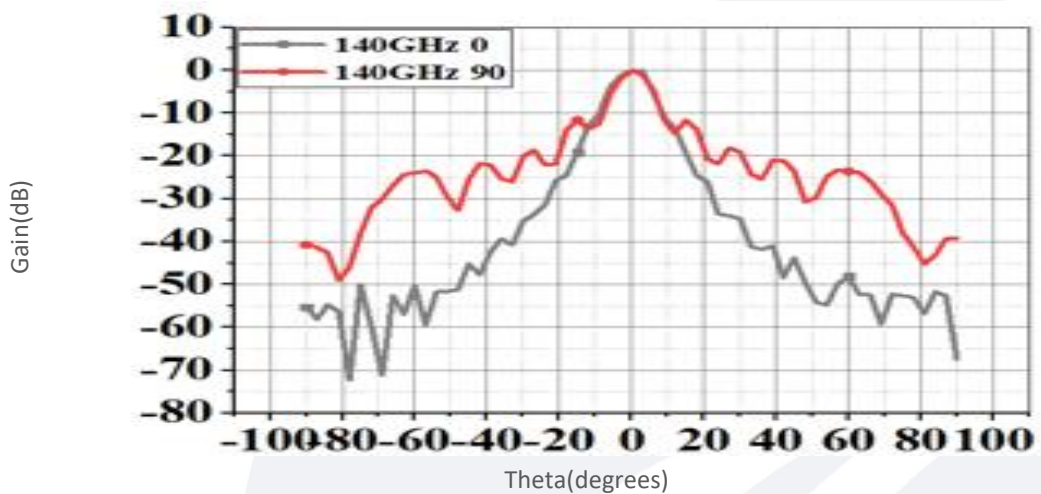

150GHz:

**Gain vs Theta**

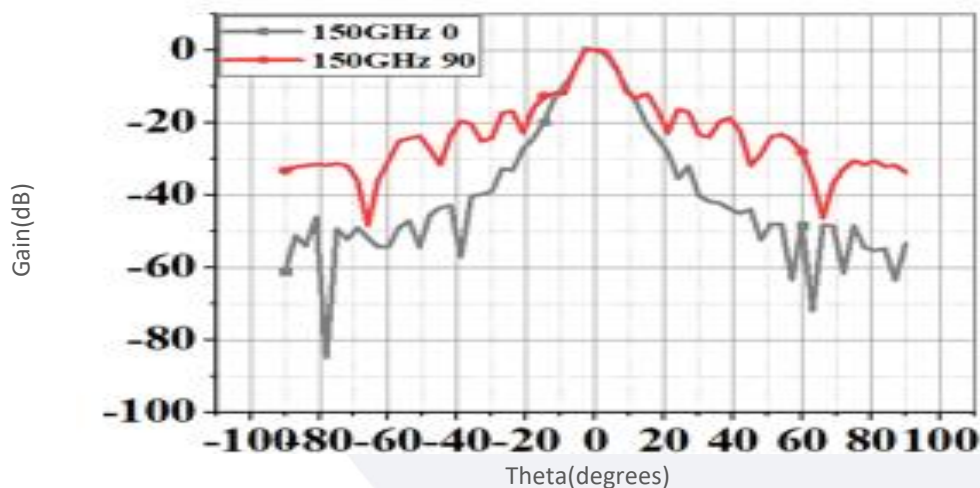

Note: Above data is for ref only, actual data may vary from unit to unit depending on operating environment and other factors like material lots etc.

**典型曲线 Typical Performance Data:**

160GHz:

**Gain vs Theta**

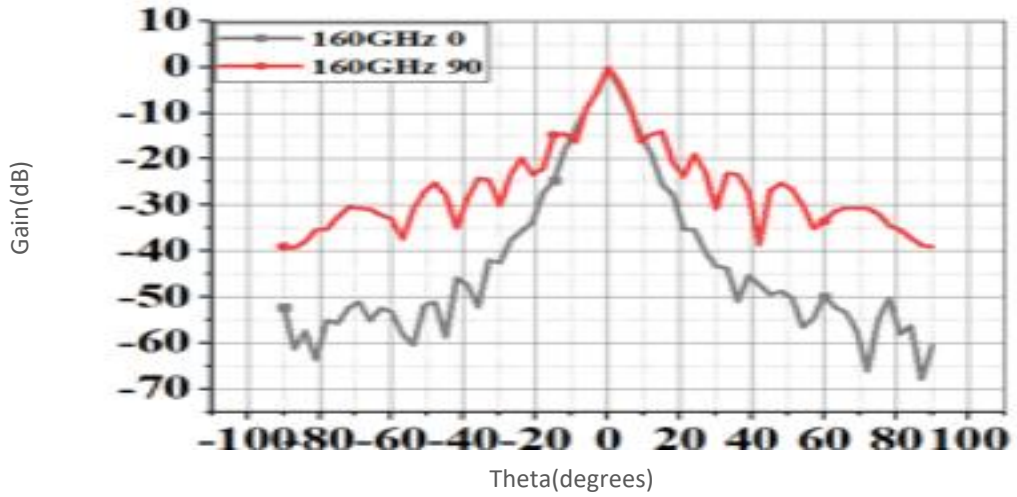

170GHz:

**Gain vs Theta**

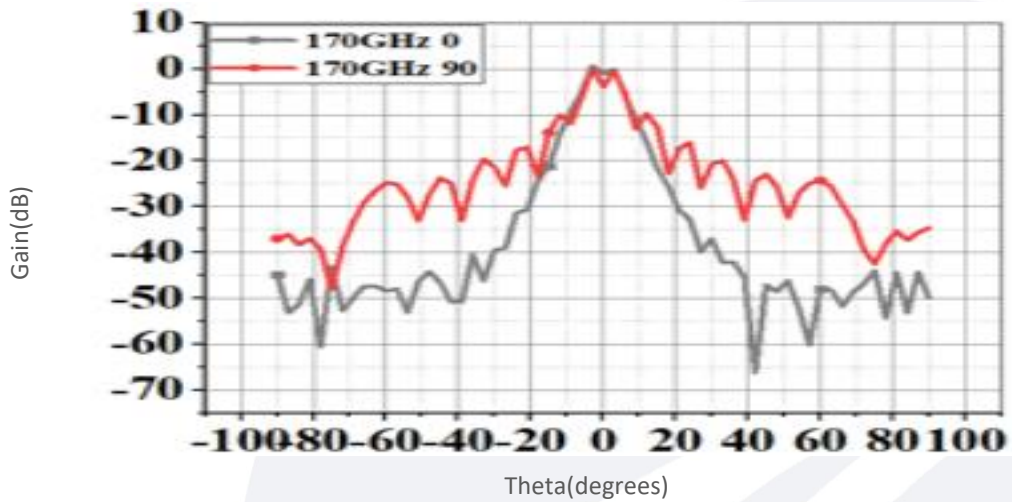

Note: Above data is for ref only, actual data may vary from unit to unit depending on operating environment and other factors like material lots etc.