

Power Amplifier

0.1-18GHz/30dB Gain/30 dBm P1dB

Model: TLPA0.1G18G-31-32

TLPA0.1G18G-31-32 is a power amplifier with a typical small signal gain of 30 dB and a minimum P1dB of 30 dBm across the frequency range of 0.1 to 18 GHz. The DC power requirement for the amplifier is +18 VDC/0.9 A. The input and output port configuration offers coax adapter structure with SMA female.

Features:

- Frequency range: 0.1-18GHz
- Gain: 30dB Typ
- Output Power P1dB: 30dBm Min
- Good Power and Gain Flatness
- 50 Ohm Matched Input / Output

Applications:

- Cellular
- PCN
- GSM
- ISM
- Lab Test

电气特性 Electrical Characteristics:

参数 Parameter	Min	Typ	Max	单位 Units
频率范围 Frequency range	0.1		18	GHz
小信号增益 Small Signal Gain*	28	30		dB
增益平坦度 Gain Flatness		±5		dB
线性输出功率 Output P1dB	30			dBm
杂散 Spurious		-60		dBc
输入驻波 Input VSWR			2.2	:1
直流电压 DC Voltage		+18		V DC
直流电流 DC Supply Current		0.9		A
阻抗 Impedance		50		Ohms

*Note: This parameters reaches 32~40dBm within the frequency range of 100MHz to 1GHz.

机械特性 Mechanical Specifications:

参数 Parameter	指标 Value	单位 Units
输入/输出接口 Input /Output Connector	SMA Femlae/SMA Female	
直流偏置 DC Bias	Solder Pin	
尺寸 Size	38*58.5*12.5	mm
重量 Weight	200	g

绝对最大值 Absolute Maximum Ratings:

参数 Parameter	指标 Value
供电偏置电压 Supply Bias Voltage	+18 V
输入功率 RF Input Power	+10 dBm
ESD灵敏度 ESD sensitivity (HBm)	Class 0, passed 150V



外形图 Outline Drawing:

Unit:mm

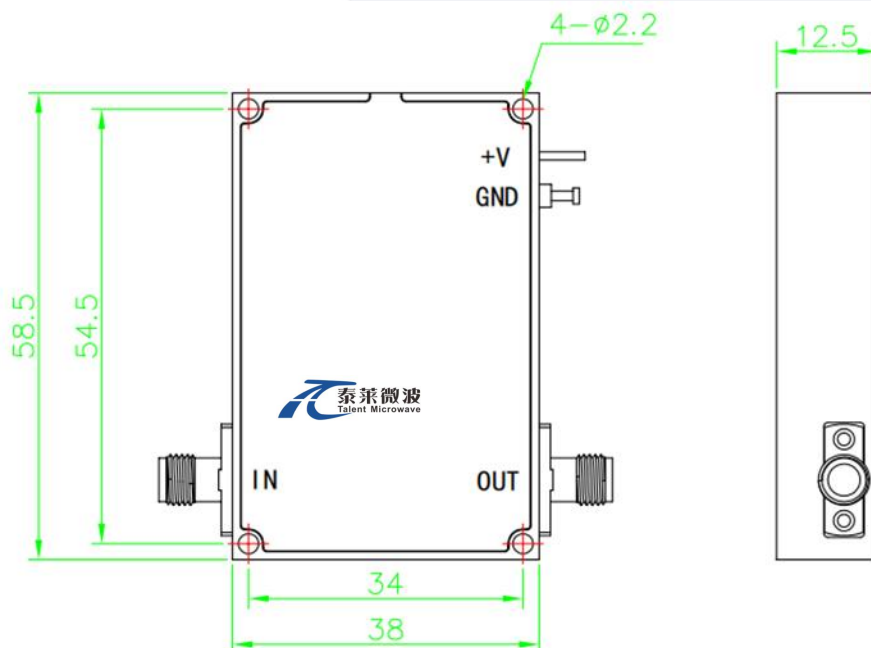

*****Heat Sink Required During Operation**



ESD Protection: Strictly adhere to ESD precautions to prevent electrostatic damage.

温度环境 Environmental Conditions:

参数 Parameter	Min	Typ	Max	单位 Units
操作温度 Operating Temperature*	-40		+60	°C
存储温度 Non-operating Temperature*	-50		+70	°C
相对湿度 Relative humidity		95		%
海拔 Altitude	10,000			feet
震动 Shock / Vibration(MIL-STD-810F)	25g rms (15 degree 2KHz) endurance, 1 hour per axis			
冲击 Shock(non operating)	20G for 11msc half sin wave,3 axis both directions			

*Note: For a wider temperature range, please consult the manufacturer.

订货信息 Ordering Information:

标准型号 Base Number	描述 Description	版本号 Revision
TLPA0.1G18G-31-32	Power amplifier 0.1-18GHz, Gain:30dB,P1dB:30dBm,+18V DC,Without Heatsink	Rev.1.1
TLPA0.1G18G-31-32-HS	Power amplifier 0.1-18GHz, Gain:30dB,P1dB:30dBm,+18V DC,With Heatsink	Rev.1.1

典型曲线 Typical Performance Data:

VSWR&Gain vs Frequency

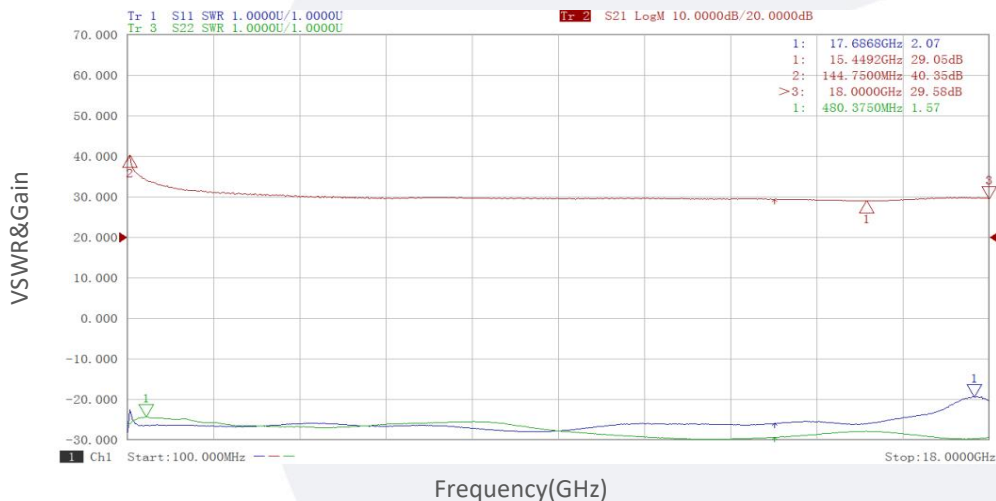

Note: Above data is for ref only, actual data may vary from unit to unit depending on operating environment and other factors like material lots etc.

典型曲线 Typical Performance Data:

Gain vs Output Power

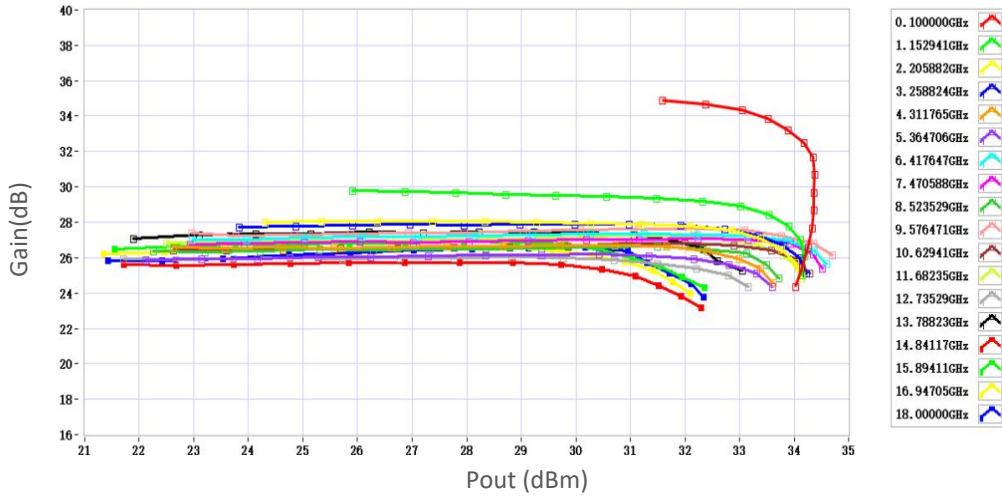

P1dB vs Frequency

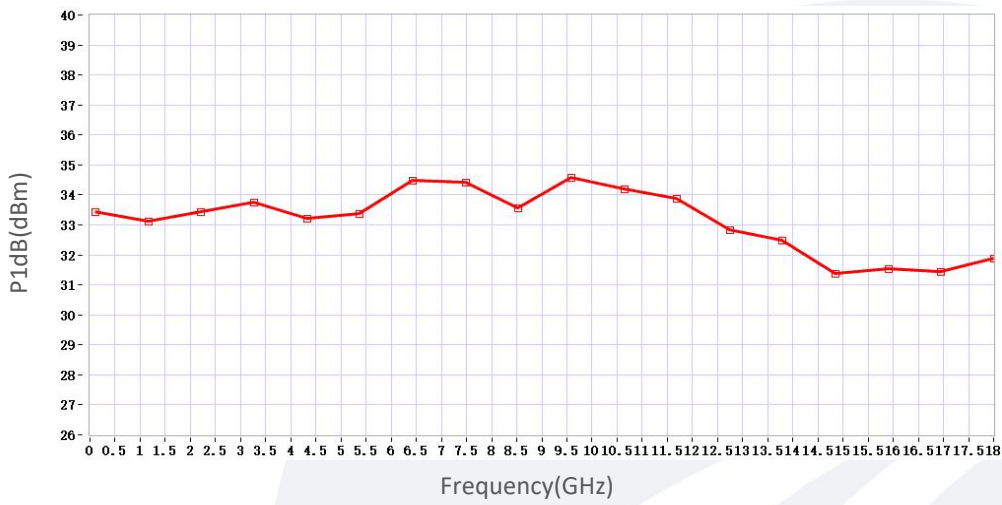

Note: Above data is for ref only, actual data may vary from unit to unit depending on operating environment and other factors like material lots etc.