

Dual Balance Mixer

RF:18-67 GHz/LO:18-67 GHz/IF:DC-21 GHz

Model: TLBM-1867-V

TLBM-1867-V is a dual balance mixer. The mixer covers the LO and RF frequency from 18 to 67 GHz with an extremely broad IF output from DC to 21 GHz. The mixer offers a conversion loss of 9 dB typical and LO input power of 15 dBm typical.

Features:

- RF/LO coverage : 18-67GHz
- IF operation : DC-21GHz
- Conversion loss: 9dB Typ
- High LO to RF isolation
- Dual Balanced Mixer

Applications:

- Defense & federal communications
- Instrumentations

电气特性 Electrical Characteristics:

参数 Parameter	Min	Typ	Max	单位 Units
RF频率 RF Frequency	18		67	GHz
LO频率 LO Frequency	18		67	GHz
LO驱动功率 LO-Input power	11	15	20	dBm
IF频率 IF Frequency	DC		21	GHz
IF输入功率 IF Input Power		-10		dBm
变频损耗 Conversion Loss		9		dB

机械特性 Mechanical Specifications:

参数 Parameter	指标 Value	单位 Units
端口1 Connector 1	1.85mm Female	
端口3 Connector 3	1.85mm Female	
端口2 Connector 2	2.92mm Female	
尺寸 Size	23.6*14.4*8	mm

接口定义 Connector Functions:

应用1

端口 Port	功能 Function
Connector 3	LO
Connector 2	IF
Connector 1	RF

应用2

端口 Port	功能 Function
Connector 3	RF
Connector 2	IF
Connector 1	LO

绝对最大值 Absolute Maximum Ratings:

参数 Parameter	指标 Value
LO功率 LO Input Power	+20 dBm
ESD灵敏度 ESD sensitivity (HBm)	Class 0, passed 150V

外形图 Outline Drawing:

Unit:mm

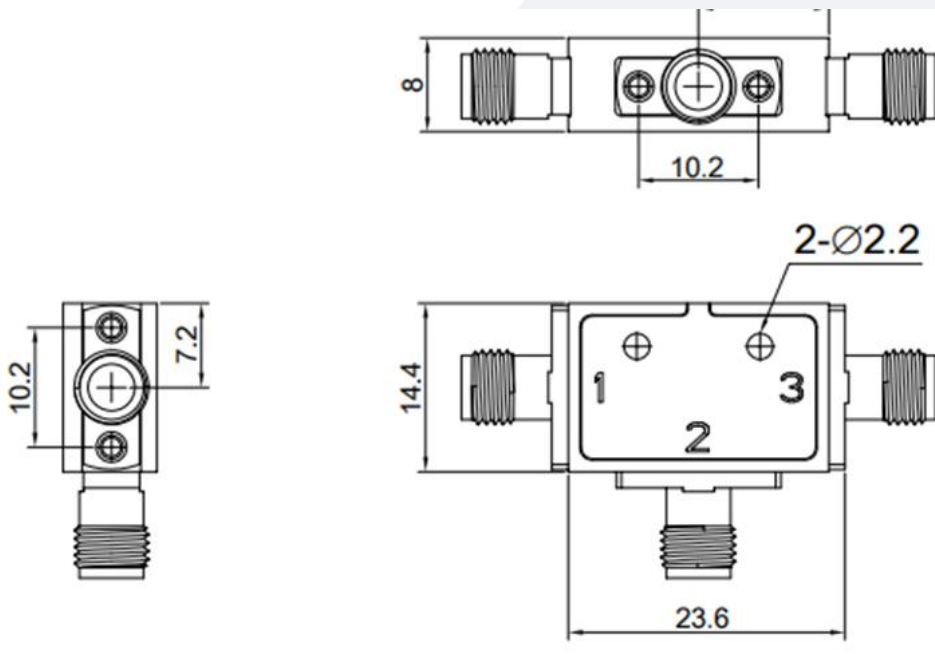

ESD Protection: Strictly adhere to ESD precautions to prevent electrostatic damage.

温度环境 Environmental Conditions:

参数 Parameter	Min	Typ	Max	单位 Units
操作温度 Operating Temperature	0		+50	°C
存储温度 Non-operating Temperature	-45		+85	°C
相对湿度 Relative humidity		95		%
海拔 Altitude	10,000			feet
震动 Shock / Vibration(MIL-STD-810F)	25g rms (15 degree 2KHz) endurance, 1 hour per axis			
冲击 Shock(non operating)	20G for 11msc half sin wave,3 axis both directions			

订货信息 Ordering Information:

标准型号 Base Number	描述 Description	版本号 Revision
TLBM-1867-V	Dual Balanced Mixer RF:18-67GHz,LO:18-67GHz,IF:DC-21GHz	Rev.1.1

杂散性能 Spurious Performance:

下变频:Down-Conversion 应用1 (2)

-10dBm RF Input	0xLO	1xLO	2xLO	3xLO	4xLO	5xLO
1xRF	40(25)	Reference	40(35)	21 (16)	45 (35)	/
2xRF	88(93)	50 (66)	67 (74)	61 (69)	68 (72)	64 (73)
3xRF	98 (90)	58 (61)	84 (84)	66 (74)	86 (85)	63 (69)
4xRF	124 (122)	89(111)	102 (110)	98 (115)	111 (119)	101 (114)
5xRF	/	117(130)	117 (130)	107 (120)	124 (127)	109 (121)

上变频:Up-Conversion 应用1 (2)

-10dBm RF Input	0xLO	1xLO	2xLO	3xLO	4xLO	5xLO
1xRF	40(25)	Reference	40 (34)	17 (14)	42 (34)	/
2xRF	70 (70)	79 (79)	68 (71)	74 (76)	57(67)	77(74)
3xRF	89 (80)	61 (69)	82 (79)	65 (64)	77(72)	54(58)
4xRF	109 (111)	106 (109)	106 (108)	105 (104)	89(99)	102 (105)
5xRF	121 (119)	105 (111)	120 (121)	103 (107)	114(112)	98 (104)

典型曲线 Typical Performance Data:

Conversion Loss vs LO Frequency

LO=15dBm, IF=-10dBm, IF=100MHz

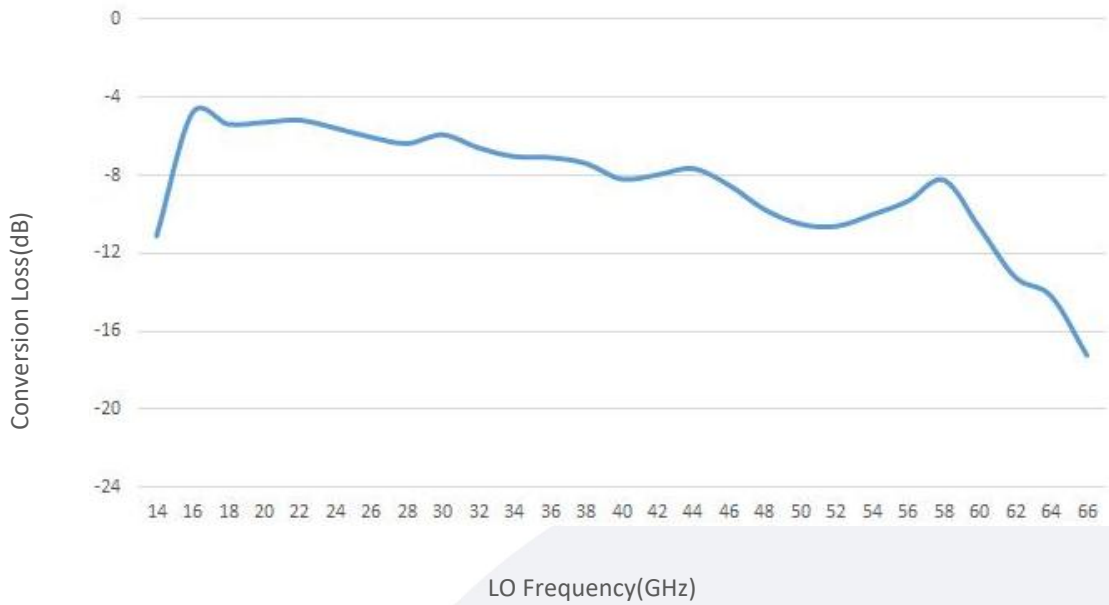

Note: Above data is for ref only, actual data may vary from unit to unit depending on operating environment and other factors like material lots etc.