

Absorptive, Broadband PIN Switch 18-67GHz/SPDT/1.85mm Female

Model: TLSPDT18G67GA

The TLSPDT18G67GA is an absorptive PIN diode based switch with a TTL driver that operates between 18 and 67 GHz. The SPDT switch offers 45 dB port-to-port isolation with a typical switching speed of 50 nanoseconds. The input and output connectors of the switch are 1.85mm female.

Features:

- Frequency range: 18-67GHz
- Insertion Loss: 5.5dB
- Power Handling: 25dBm
- High Isolation
- Switch Type: Absorptive

Applications:

- Communication Systems
- Automatic Test Equipment
- Switching Network

Electrical Characteristics:

Parameter	Min	Typ	Max	Units
Frequency range	18		67	GHz
Insertion Loss		5.5		dB
Isolation	45			dB
Switch Speed		50	100	ns
Input VSWR		2		:1
Output VSWR		2		:1
Power Handling			25	dBm
Input P1dB		20		dBm
DC Supply Voltage		+5/-5		V DC
DC Supply Current		50		mA
Switch type	Absorptive			
Impedance	50			Ohms

Absolute Maximum Ratings :

Description	Parameter	Units
Supply Bias Voltage	±5%	V
RF Input Power	25	dBm
ESD sensitivity (HBm)	Class 0, passed 150V	

Mechanical Specifications:

Description	Parameter	Units
Input /Output Connector	1.85mm Female/1.85mm Female	
Control Bias Connector	Solder Pin	
Size	29.6*24.6*10	mm

Outline Drawing:

Unit:mm

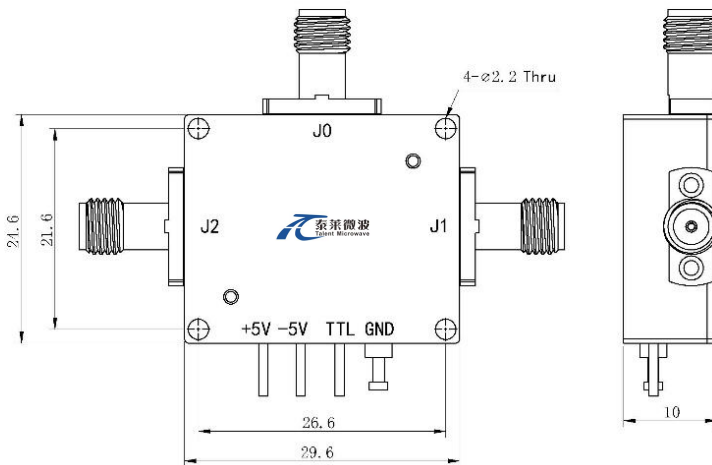

Truth Table	
TTL Control Input	Signal Path State
0	J0-J1
1	J0-J2

TTL Control Voltages &VDD	
Stage	Bias Condition
VDD	+5V (±5%)
VEE	-5V (±5%)
Low (0)	0 to 0.8Vdc
High (1)	+3.3 to +5.0Vdc

1. Dimensions are in mm [inches]

2. Tolerances: Outline drawing ±0.2 [0.008] Hole ±0.2 [0.008]

NOTE: ALL SPECIFICATIONS ARE SUBJECT TO CHANGE WITHOUT NOTICE AT ANY TIME



ESD Protection: Strictly adhere to ESD precautions to prevent electrostatic damage.

Environmental Conditions:

Parameter	Min	Typ	Max	Units
Operating Temperature	-45		+85	°C
Non-operating Temperature	-55		+125	°C
Relative humidity		95		%
Altitude	10,000			feet
Shock / Vibration(MIL-STD-810F)	25g rms (15 degree 2KHz) endurance, 1 hour per axis			
Shock(non operating)	20G for 11msc half sin wave,3 axis both directions			

Ordering Information:

Base Number	Description	Revision
TLSPDT18G67GA	Absorptive,Broadband PIN Switch 18-67GHz,SPDT,1.85mm	Rev.1.0