

Power Amplifier

18-26.5GHz/18dB Gain/32dBm Psat

Model: TLPA18G26.5G-18-30

TLPA18G26.5G-18-30 is a power amplifier with a typical small signal gain of 18 dB and a nominal Psat of 32 dBm across the frequency range of 18 to 26.5 GHz. The DC power requirement for the amplifier is +12 VDC/860 mA. The input and output port configuration offers coax adapter structure with 2.92mm female.

Features:

- Frequency range: 18-26.5GHz
- Gain: 18dB Typ
- Output Power Psat: 32dBm Typ
- Good Power and Gain Flatness
- 50 Ohm Matched Input / Output

Applications:

- Cellular
- PCN
- GSM
- ISM
- Lab Test

Electrical Characteristics:

Parameter	Min	Typ	Max	Units
Frequency range	18		26.5	GHz
Small Signal Gain		18		dB
Gain Flatness		±2	±2.5	dB
Output P1dB	30	31		dBm
Output Psat		32		dBm
VSWR		2	2.2	:1
DC Voltage		12		V DC
DC Supply Current		860		mA
Impedance		50		Ohms

Mechanical Specifications:

Parameter	Value	Units
Input /Output Connector	2.92mm Female/2.92mm Female	
DC Bias	Feedthru capacitors	
Size	60*60*11(Without heatsink) 188*125*146(With heatsink)	mm
Weight	200	g

Absolute Maximum Ratings:

Parameter	Value
Supply Bias Voltage	TBD
RF Input Power	+15 dBm
ESD sensitivity (HBm)	Class 0, passed 150V

Outline Drawing:

Unit:mm

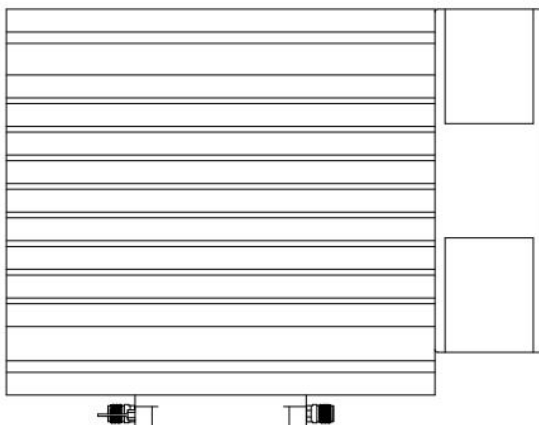
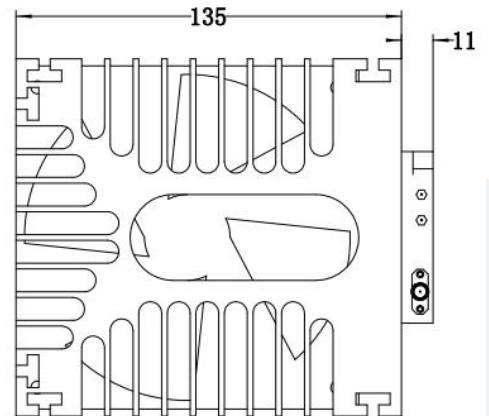
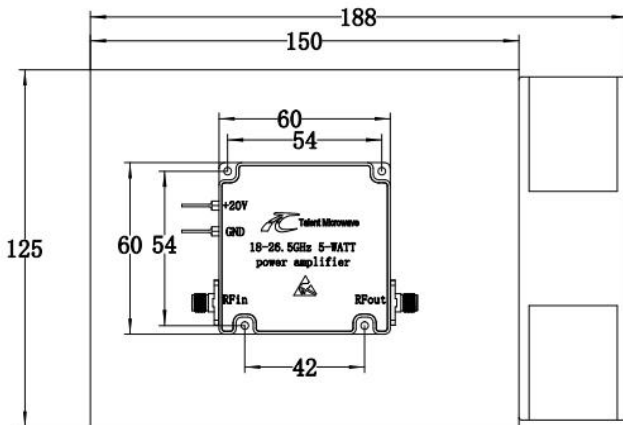

ESD Protection: Strictly adhere to ESD precautions to prevent electrostatic damage.

Environmental Conditions:

Parameter	Min	Typ	Max	Units
Operating Temperature*	-40		+60	°C
Non-operating Temperature*	-50		+70	°C
Relative humidity		95		%
Altitude	10,000			feet
Shock / Vibration(MIL-STD-810F)	25g rms (15 degree 2KHz) endurance, 1 hour per axis			
Shock(non operating)	20G for 11msc half sin wave,3 axis both directions			

*Note: For a wider temperature range, please consult the manufacturer.

Ordering Information:

Base Number	Description	Revision
TLPA18G26.5G-18-30	Power amplifier 18-26.5GHz, Gain:18dB,Psat:32dBm,+12V DC,Without Heatsink	Rev.1.2
TLPA18G26.5G-18-30-HS	Power amplifier 8-26.5GHz, Gain:18dB,Psat:32dBm,+12V DC,With Heatsink	Rev.1.2

Typical Performance Data:

VSWR&Gain vs Frequency

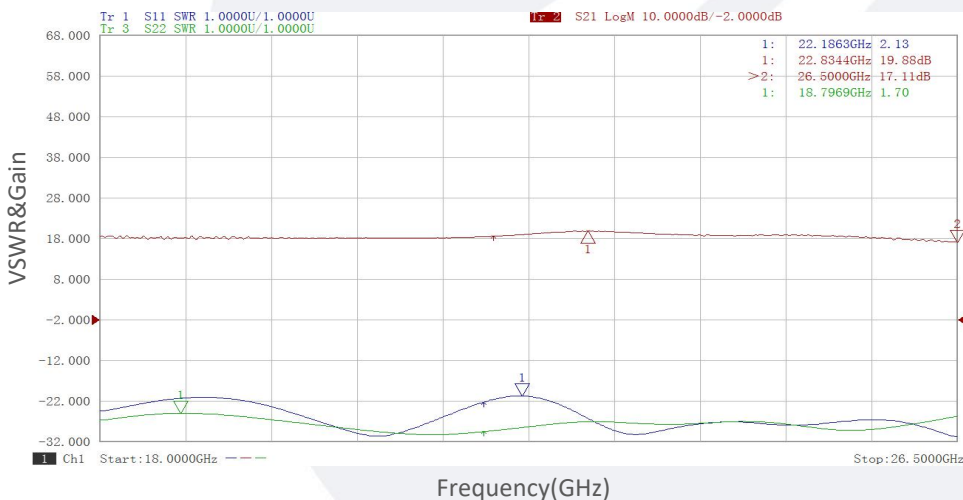

Note: Above data is for ref only, actual data may vary from unit to unit depending on operating environment and other factors like material lots etc.

Typical Performance Data:

Gain vs Output Power

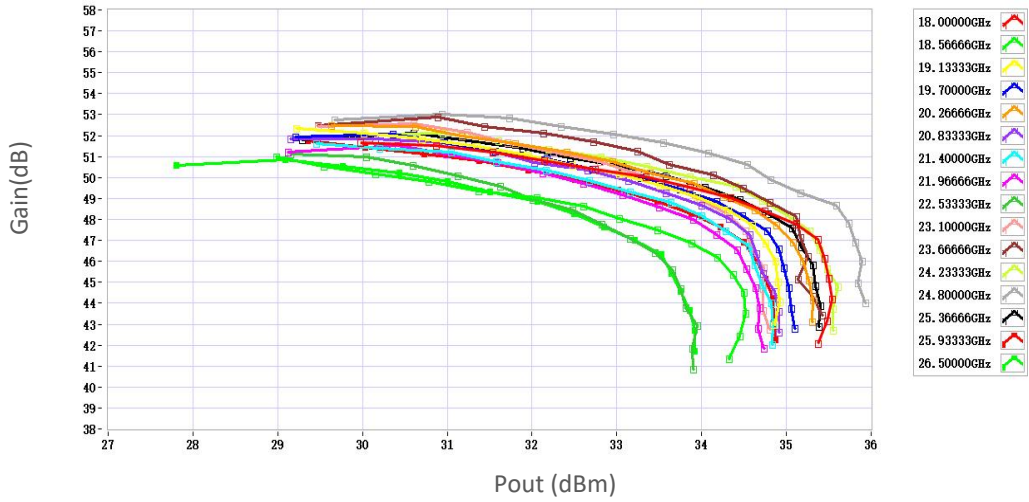

P1dB vs Frequency

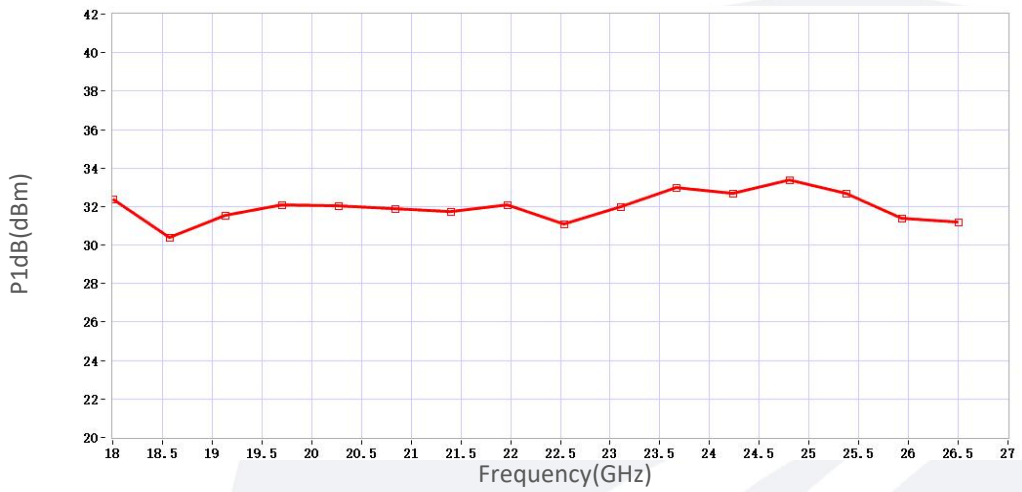

P3dB vs Frequency

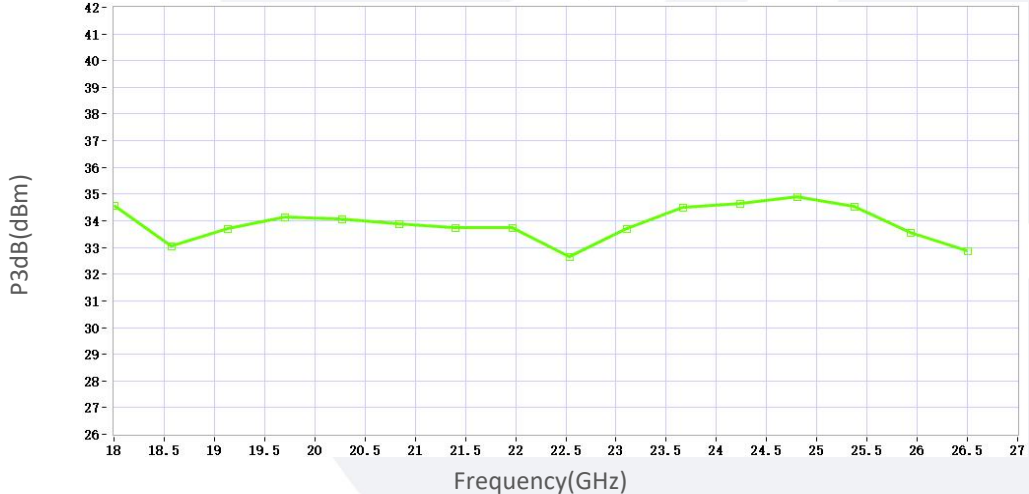

Note: Above data is for ref only, actual data may vary from unit to unit depending on operating environment and other factors like material lots etc.

Typical Performance Data:

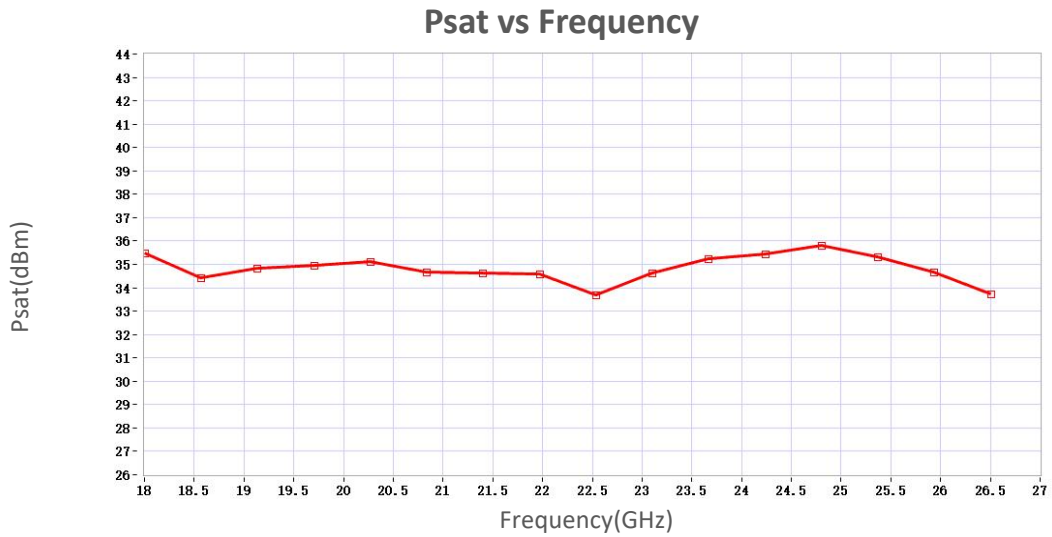

Note: Above data is for ref only, actual data may vary from unit to unit depending on operating environment and other factors like material lots etc.