

**Model: TLSP4T0.1G18GA**
**Absorption, Broadband MMIC Switch  
 0.1-18 GHz, SP4T, SMA**
**Feature:**

- Ultra Wide Band: 0.1-18 GHz
- Low Insertion Loss: 3.5 dB
- Power Handling : 27 dBm
- High Isolation
- Switch Type: Absorption

**Electrical Specifications:**

Parameter	Min	Typ	Max	Units
Frequency range	0.1-18			GHz
Insertion Loss		3.5	5.5	dB
Isolation		65		dB
Switch Speed		50	100	ns
Input VSWR		2.0	3.0	:1
Output VSWR		2.0	3.0	:1
Power Handling			27	dBm
DC Voltage		+5		V DC
DC Supply Current		20		mA
Impedance	50			Ohms

**Mechanical Specifications:**

Parameter	Value	Units
Input /Output Connector	SMA Female	
Control Bias	Solder Pin	
Size	50.8*30*10.2	mm
Weight	-	g

**Absolute Maximum Ratings:**

Parameter	Value
Supply Bias Voltage	+/-5%
RF Input Power	30 dBm
ESD sensitivity (HBm)	Class 0, passed 150V

**Outline Drawing:**

Unit: mm

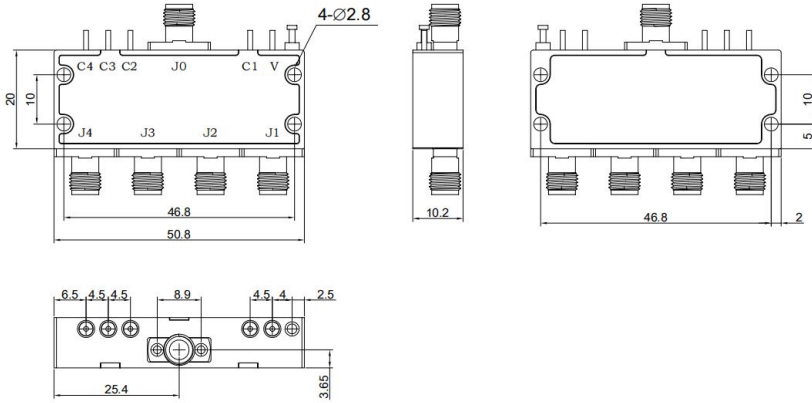

Truth Table				
TTL Control Input				Signal Path State
C4	C3	C2	C1	
0	0	0	1	J0-J1
0	0	1	0	J0-J2
0	1	0	0	J0-J3
1	0	0	0	J0-J4
1: +3.3V/+5V 0:0V				

1. Dimensions are in mm [inches]
  2. Tolerances: Outline drawing  $\pm 0.2$  [0.008] Hole  $\pm 0.2$  [0.008]
- NOTE: ALL SPECIFICATIONS ARE SUBJECT TO CHANGE WITHOUT NOTICE AT ANY TIME



**Environmental Conditions:**

Parameter	Min	Typ	Max	Units
Operating Temperature	-20		+70	°C
Non-operating Temperature	-55		+125	°C
Relative humidity		95		%
Altitude		50,000		feet
Shock / Vibration(MIL-STD-810F)	25g rms (15 degree 2KHz) endurance, 1 hour per axis			
Shock(non operating)	20G for 11msc half sin wave,3 axis both directions			

**Ordering Information:**

Part Number	Description	Revision
TLSP4T0.1G18GA	Absorption, Broadband MMIC Switch 0.1-18 GHz, SP4T, SMA	Rev.1.1

Typical Performance Data:

Insertion Loss&VSWR vs Frequency

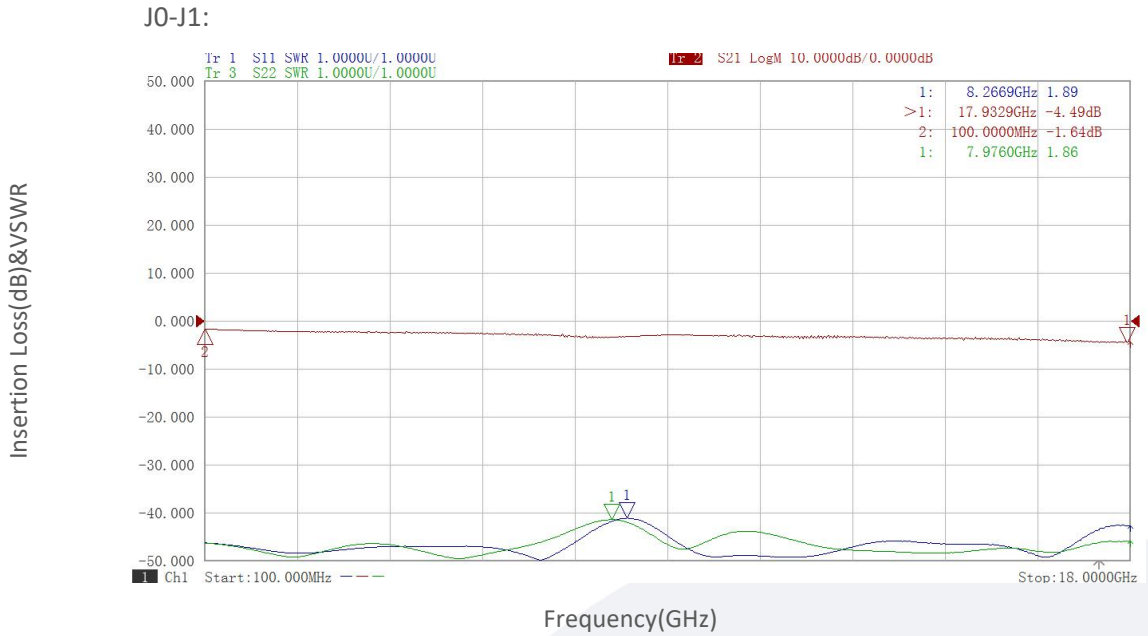

Isolation vs Frequency

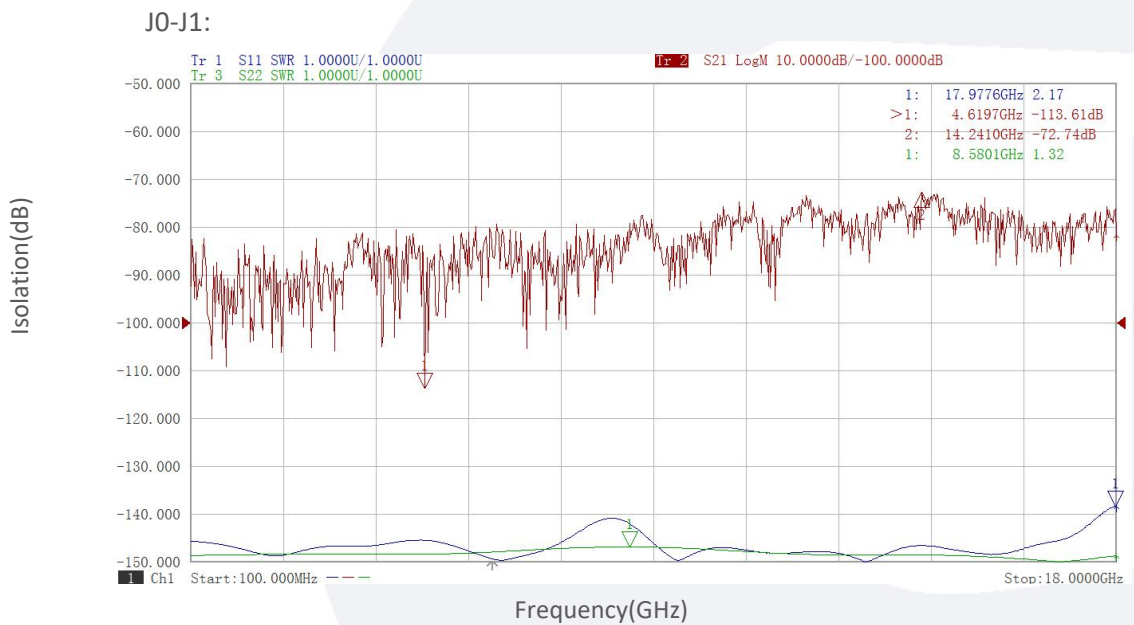

Note: Above data is for ref only, actual data may vary from unit to unit depending on operating environment and other factors like material lots etc.

Typical Performance Data:

Insertion Loss&VSWR vs Frequency

J0-J2:

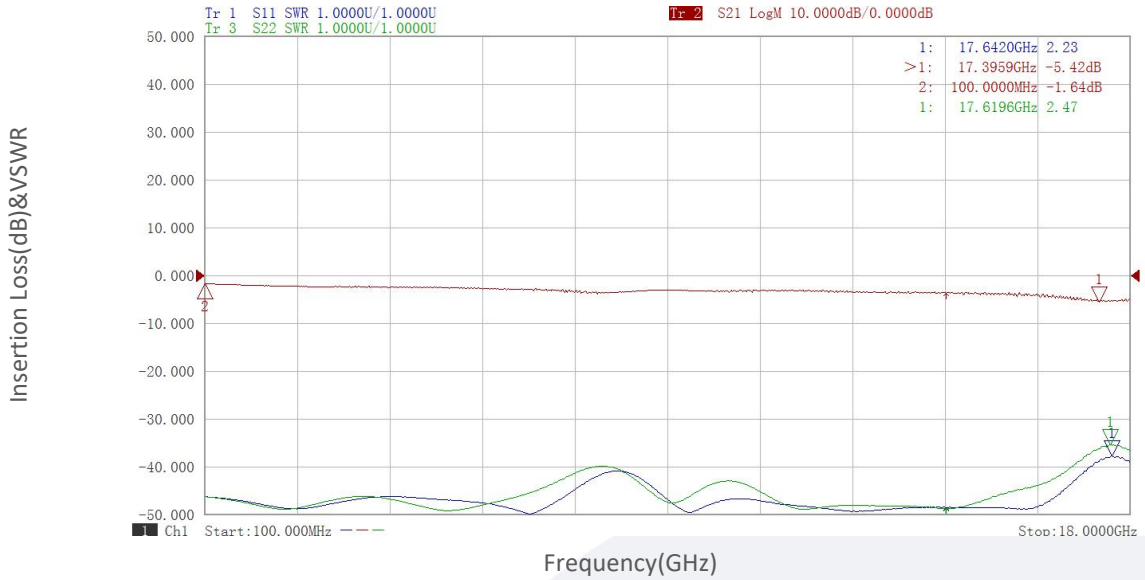

Isolation vs Frequency

J0-J2:

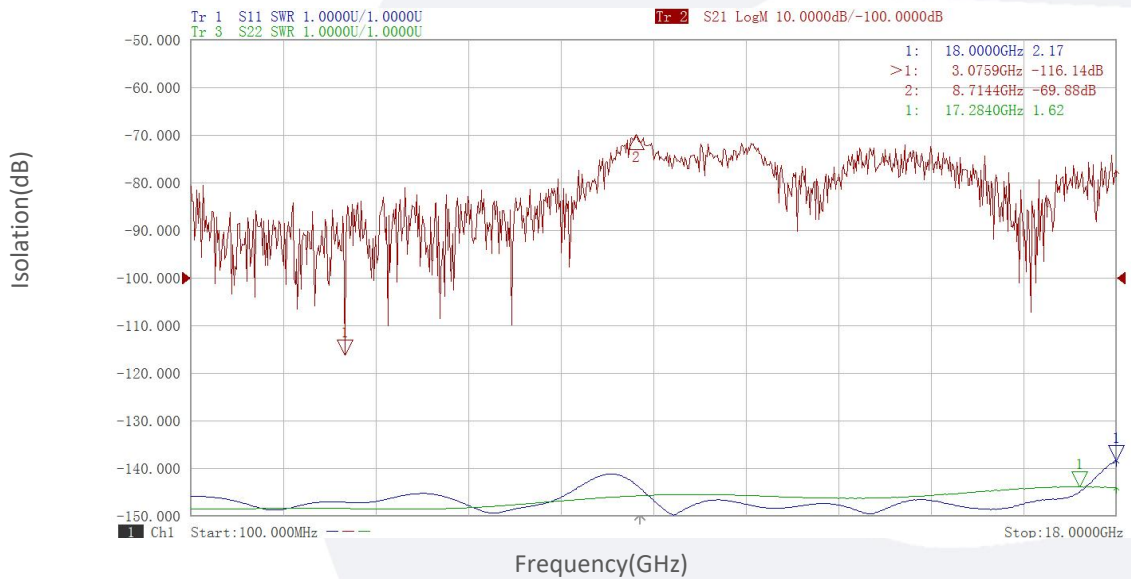

Note: Above data is for ref only, actual data may vary from unit to unit depending on operating environment and other factors like material lots etc.

Typical Performance Data:

Insertion Loss&VSWR vs Frequency

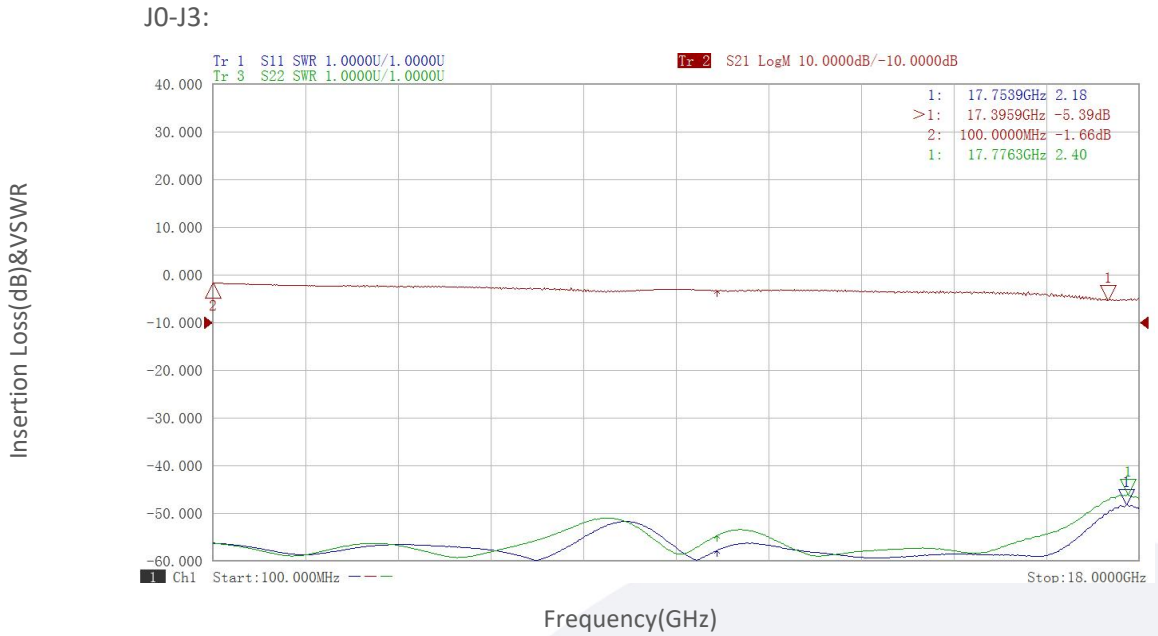

Isolation vs Frequency

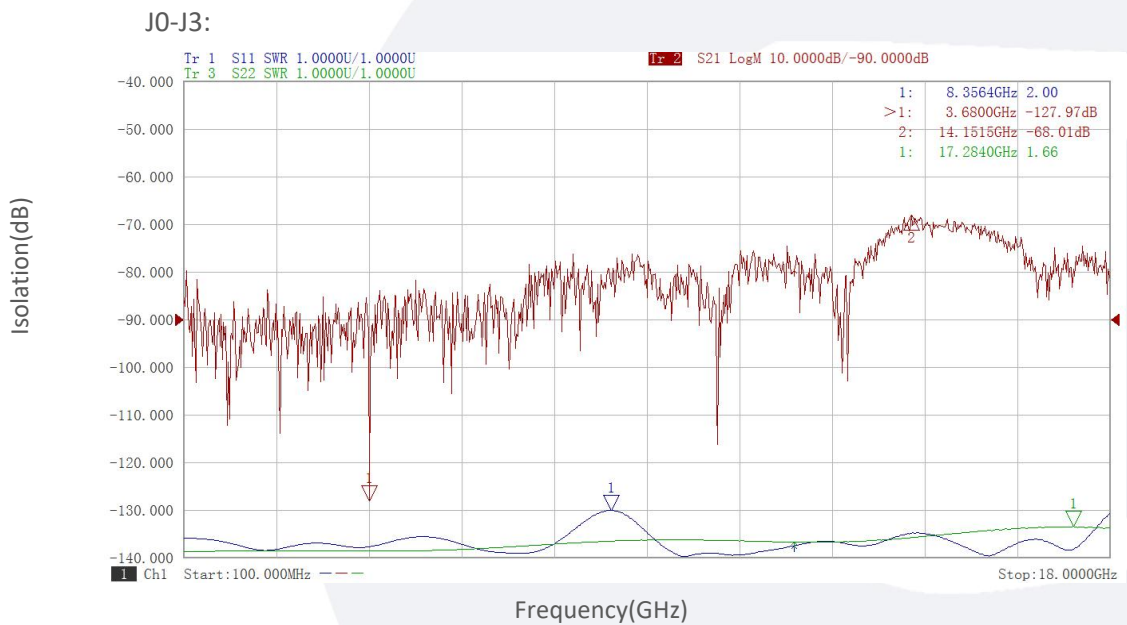

Note: Above data is for ref only, actual data may vary from unit to unit depending on operating environment and other factors like material lots etc.

Typical Performance Data:

Insertion Loss&VSWR vs Frequency

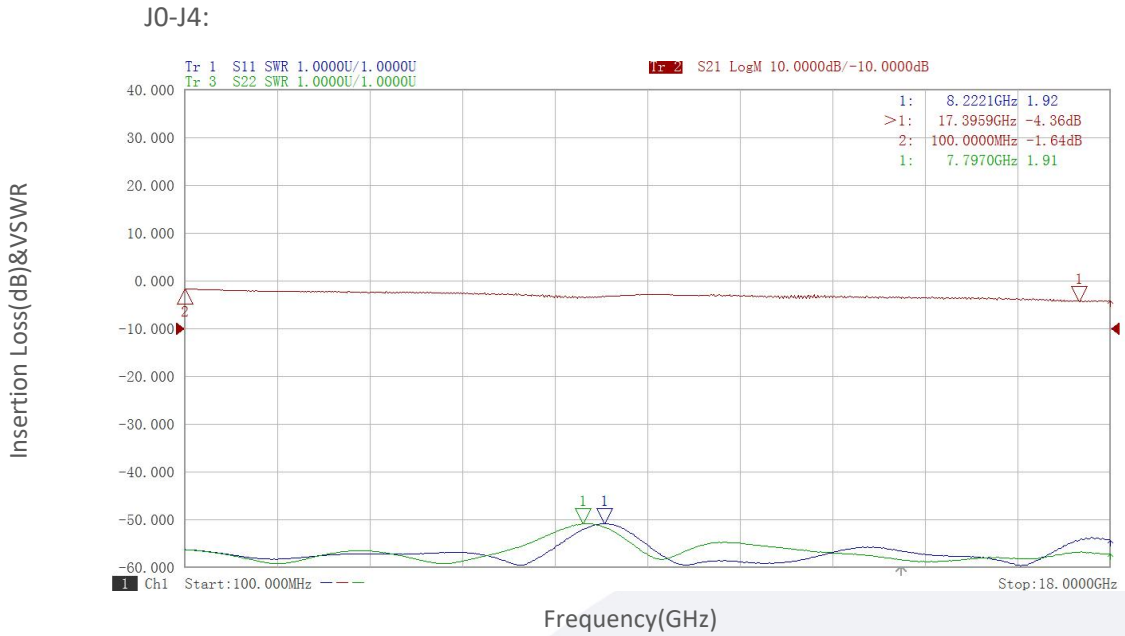

Isolation vs Frequency

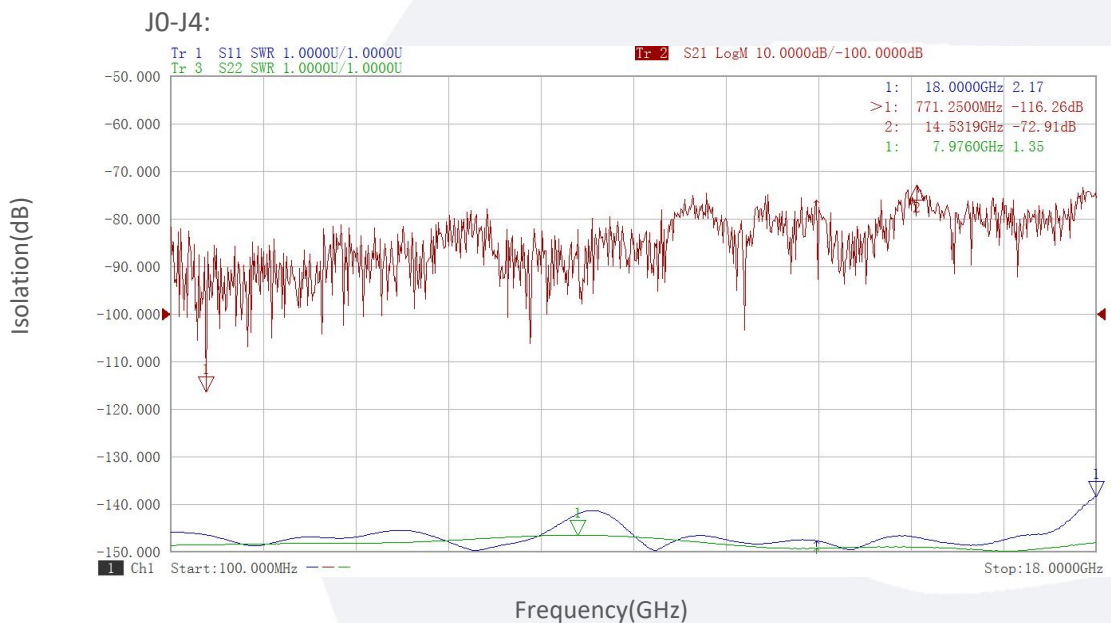

Note: Above data is for ref only, actual data may vary from unit to unit depending on operating environment and other factors like material lots etc.

Typical Performance Data:

Isolation vs Frequency

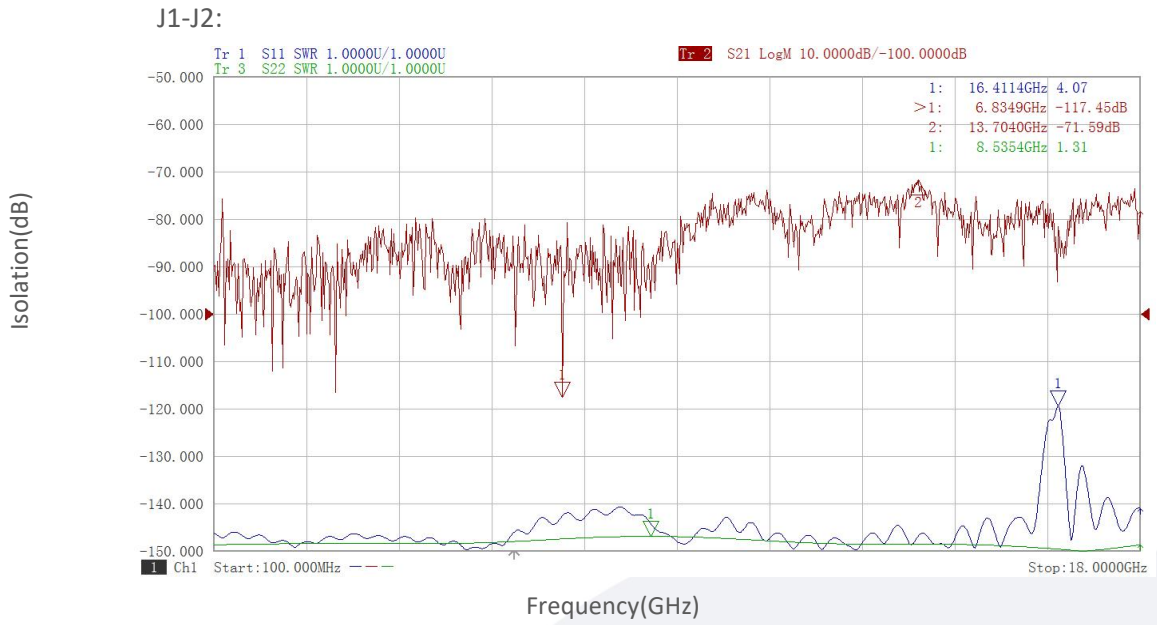

Isolation vs Frequency

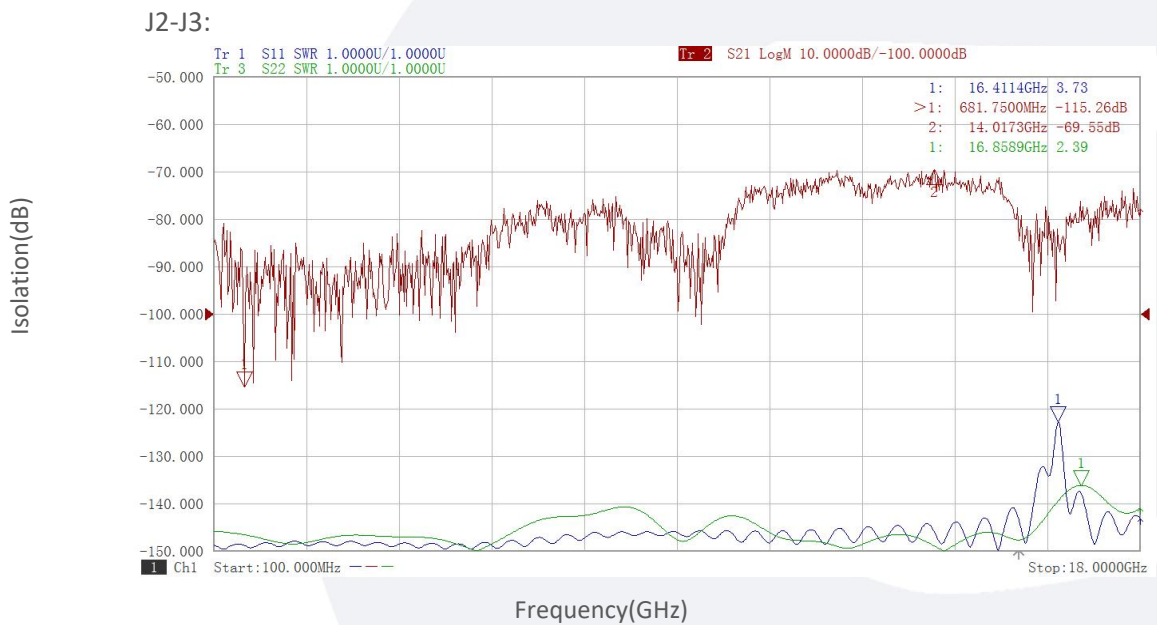

Note: Above data is for ref only, actual data may vary from unit to unit depending on operating environment and other factors like material lots etc.



Typical Performance Data:

Isolation vs Frequency

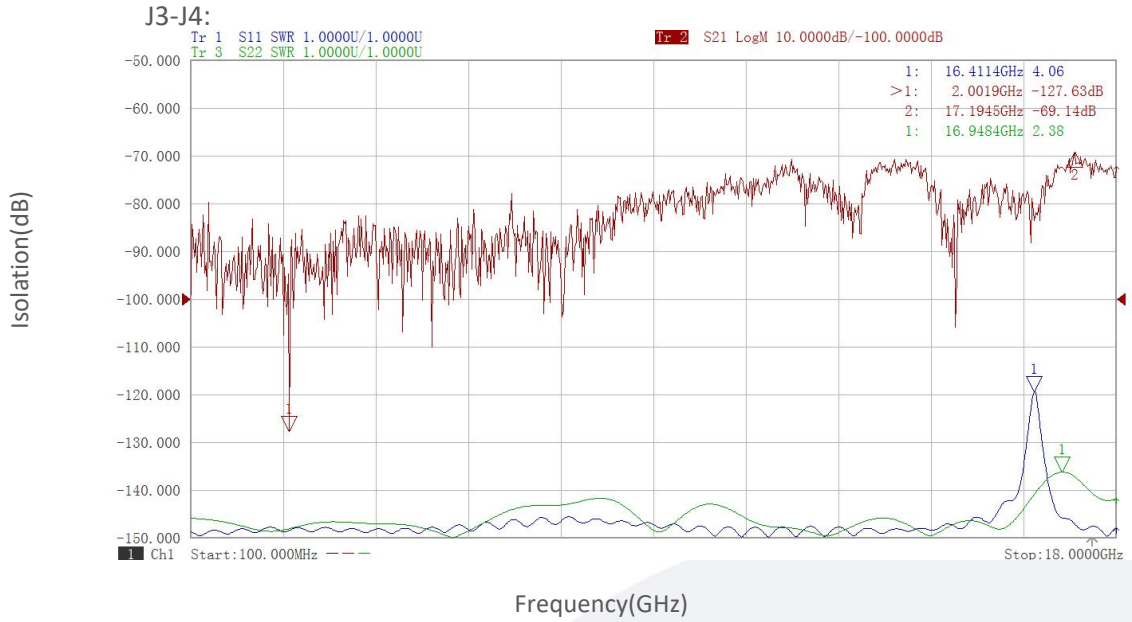

Note: Above data is for ref only, actual data may vary from unit to unit depending on operating environment and other factors like material lots etc.