

Model: TLLA4G8G-45-07

Low Noise Amplifier

4-8GHz, NF:0.9dB, Gain:45dB, P1dB:16dBm

Feature:

- Ultra Wide Band: 4-8GHz
- Gain: 45dB Typ
- Noise Figure: 0.9dB Typ
- Good Power and Gain Flatness
- 50 Ohm Matched Input / Output

Electrical Specifications:

Parameter	Min	Typ	Max	Units
Frequency range	4-8			GHz
Gain	43	45		dB
Gain Flatness		±1	±1.5	dB
Noise Figure		0.9	1.2	dB
Output P1dB	14	16		dBm
Input VSWR		1.5	2	:1
Output VSWR		1.5	2.2	:1
DC Voltage	8	12	15	V DC
DC Supply Current		70		mA
Impedance	50			Ohms

Mechanical Specifications:

Parameter	Value	Units
Input /Output Connector	SMA Female/SMA Female	
DC Bias	Solder Pin	
Size	44.8*29.2*11	mm
Weight	55	g

Absolute Maximum Ratings:

Parameter	Value
Supply Bias Voltage	+15V
RF Input Power	12 dBm
ESD sensitivity (HBm)	Class 0, passed 150V



**Available 220V System
Benchtop Amplifier**

Outline Drawing:

Unit: mm(inches)

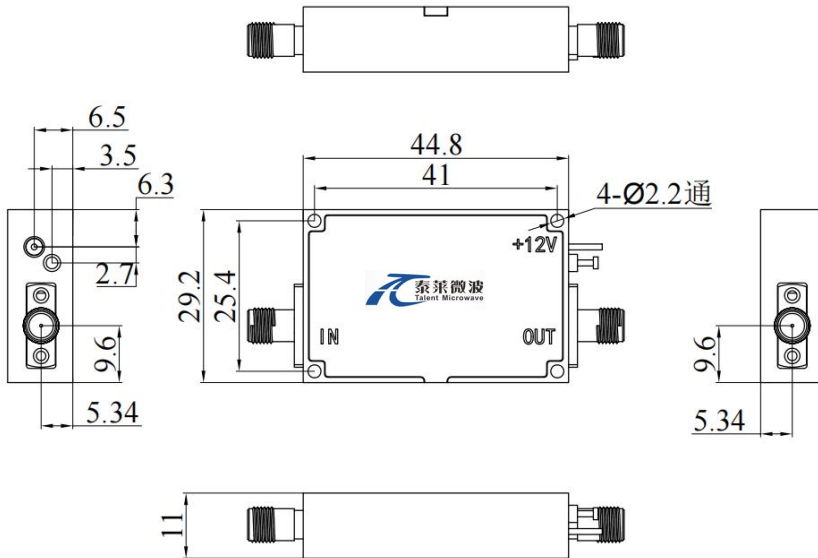

*****Heat Sink Required During Operation**



OBSERVE PRECAUTIONS
ELECTROSTATIC SENSITIVE
DEVICES

Environmental Conditions:

Parameter	Min	Typ	Max	Units
Operating Temperature	-45		+85	°C
Non-operating Temperature	-55		+125	°C
Relative humidity		95		%
Altitude	50,000			feet
Shock / Vibration(MIL-STD-810F)	25g rms (15 degree 2KHz) endurance, 1 hour per axis			
Shock(non operating)	20G for 11msc half sin wave,3 axis both directions			

Ordering Information:

Part Number	Description	Revision
TLLA4G8G-45-07	Low Noise Amplifier, 4-8GHz, Noise Figure:0.9dB, Gain:45 dB,P1dB:16dBm,+12V DC,Without Heatsink	Rev.1.1
TLLA4G8G-45-07-HS	Low Noise Amplifier, 4-8GHz, Noise Figure:0.9dB, Gain:45 dB,P1dB:16dBm,+12V DC,With Heatsink	Rev.1.1

Typical Performance Data:

Gain&VSWR vs Frequency

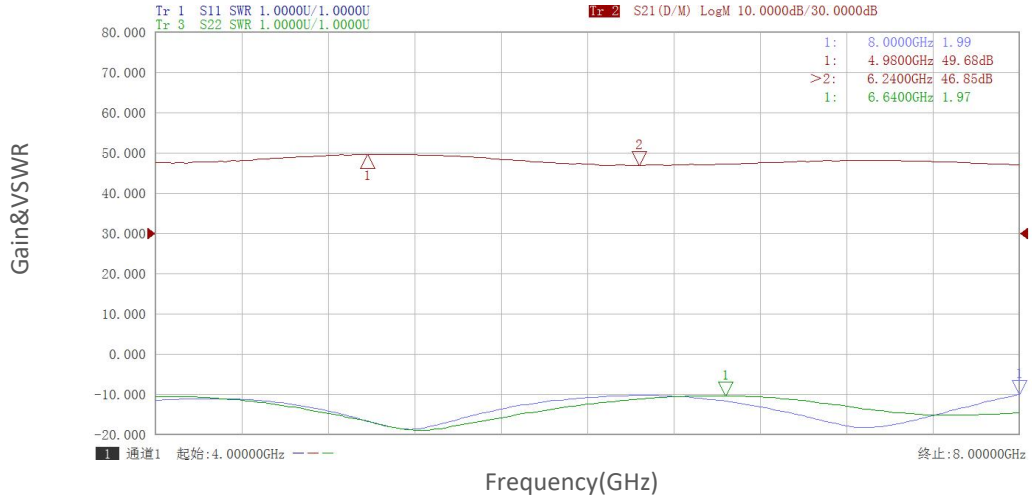

Noise Figure vs Frequency

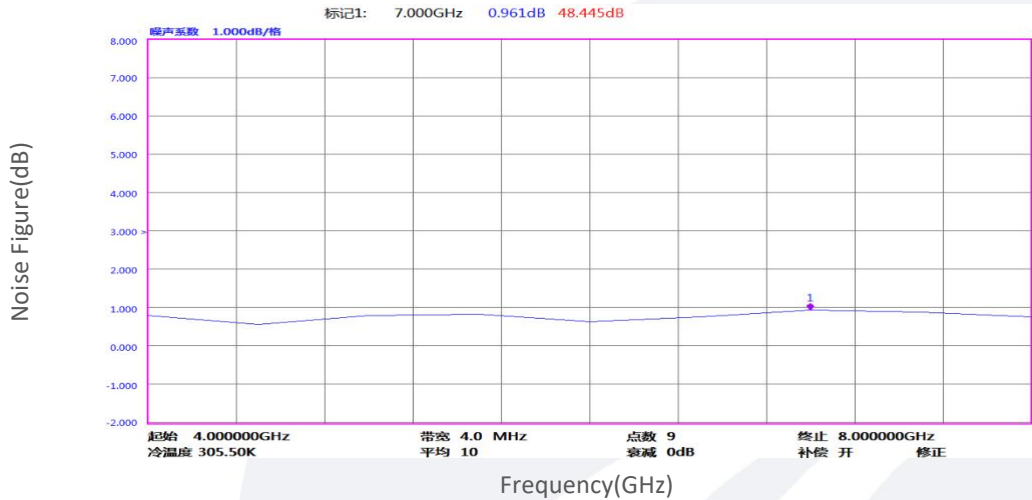

Gain vs Output Power

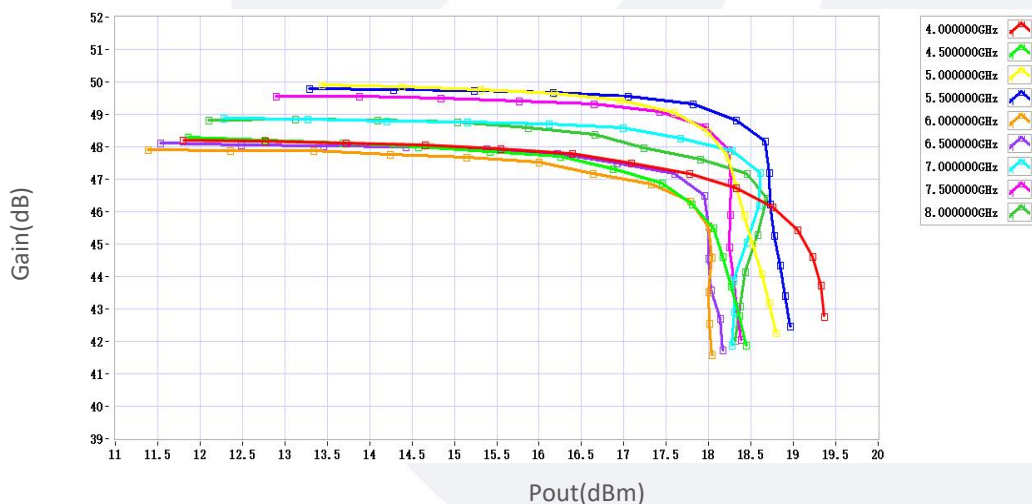

Typical Performance Data:

P1dB vs Frequency

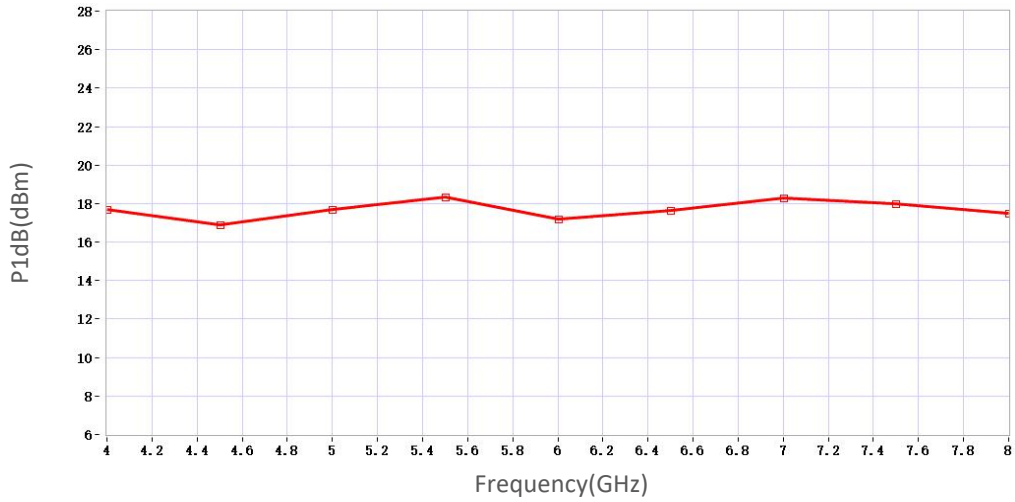

P3dB vs Frequency

