

Model: TMPA-060090-3520-12
Power Amplifier
60-90GHz, Gain:35 dB, Psat:20 dBm
Feature:

- Frequency Range: 60-90 GHz
- Gain:35 dB Type
- Output Power Psat:20 dBm Type
- Good Power and Gain Flatness

Electrical Specifications:

Parameter	Min	Typ	Max	Units
Frequency range	60-90			GHz
Small Signal Gain		34		dB
Gain Flatness		±2.0		dB
Output Psat		20		dBm
Input VSWR		2		:1
Output VSWR		2.5		:1
DC Voltage		12		V DC
DC Supply Current		310		mA

Mechanical Specifications:

Parameter	Value	Units
Input /Output Connector	WR-12/UG-387/U	
DC Bias	Solder Pin	
Size	45*30*23	mm
Weight	/	g

Absolute Maximum Ratings:

Parameter	Value
Supply Bias Voltage	+15 V
RF Input Power	15 dBm
ESD sensitivity (HBm)	Class 0, passed 150V

**Available 220V System
 Benchtop Amplifier**

Outline Drawing:

Unit: mm

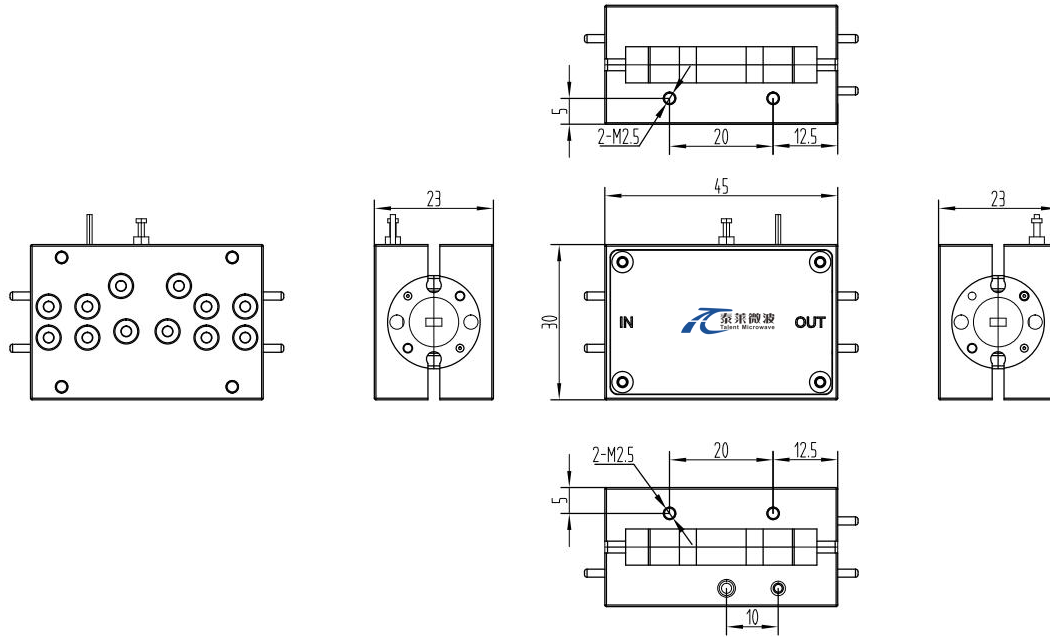

OBSERVE PRECAUTIONS
ELECTROSTATIC SENSITIVE
DEVICES

Environmental Conditions:

Parameter	Min	Typ	Max	Units
Operating Temperature	-10		+65	°C
Non-operating Temperature	-55		+125	°C
Relative humidity		95		%
Altitude	50,000			feet
Shock / Vibration(MIL-STD-810F)	25g rms (15 degree 2KHz) endurance, 1 hour per axis			
Shock(non operating)	20G for 11msc half sin wave,3 axis both directions			

Ordering Information:

Part Number	Description	Revision
TMPA-060090-3520-12	Power Amplifier, 60-90 GHz, Gain:34 dB Type, Psat:20 dBm Type, +12V DC,WR-12	Rev.1.1

Typical Performance Data:

Gain vs Frequency

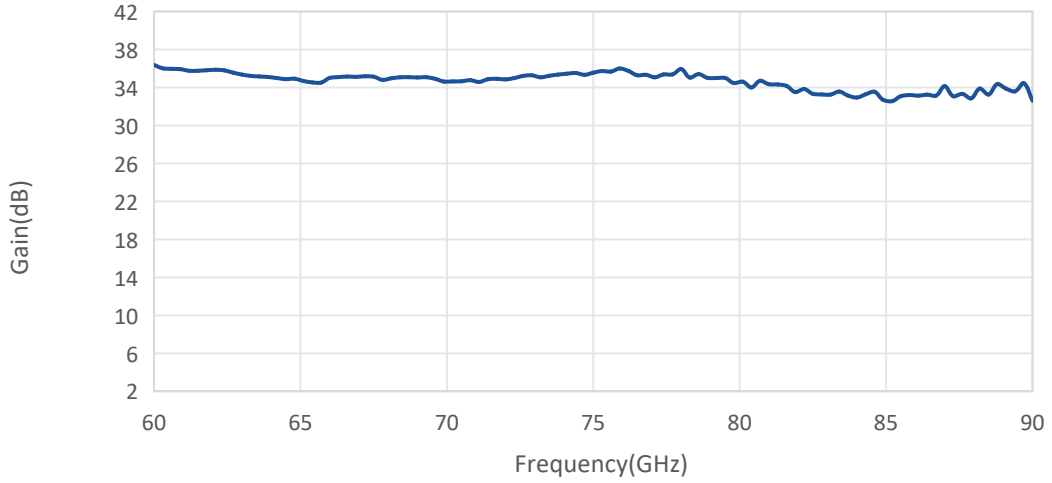

Input VSWR vs Frequency

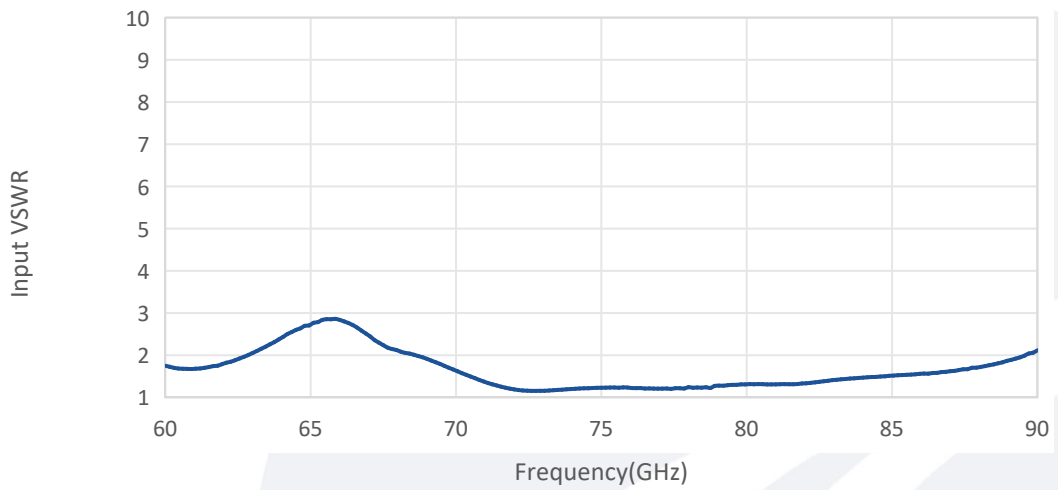

Psat vs Frequency

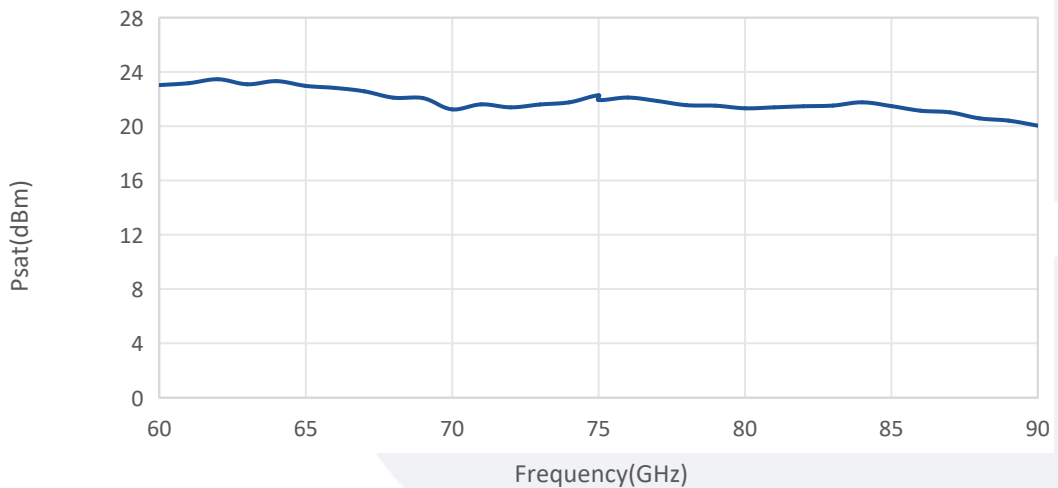

Note: Above data is for ref only, actual data may vary from unit to unit depending on operating environment and other factors like material lots etc.