

Model: TLLA50K20G-35-30

**Low Noise Amplifier 50KHz-20GHz,
NF:3.0dB, Gain:35dB, P1dB:15dBm**

Feature:

- Ultra Wide Band: 50KHz-20GHz
- Gain: 35dB Typ
- Noise Figure: 3.0dB Typ
- Good Power and Gain Flatness
- 50 Ohm Matched Input / Output

Electrical Specifications:

Parameter	Min	Typ	Max	Units
Frequency range	50KHz-20GHZ			GHz
Gain	35	37		dB
Gain Flatness		±1.5		dB
Noise Figure		3		dB
Output P1dB		15		dBm
Input VSWR			2	:1
Output VSWR			2	:1
DC Voltage	+10	+12	+15	V DC
DC Supply Current		150		mA
Impedance	50			Ohms

机械特性 Mechanical Specifications:

Parameter	Value	Units
Input /Output Connector	2.92mm Female/2.92mm Female	
DC Bias	Solder Pin	
Size	44.8*29.2*11	mm
Weight	55	g

Absolute Maximum Ratings:

Parameter	Value
Supply Bias Voltage	+15V
RF Input Power	15 dBm
ESD sensitivity (HBM)	Class 0, passed 150V



Available 220V System
Benchtop Amplifier

Outline Drawing:

Unit: mm(inches)

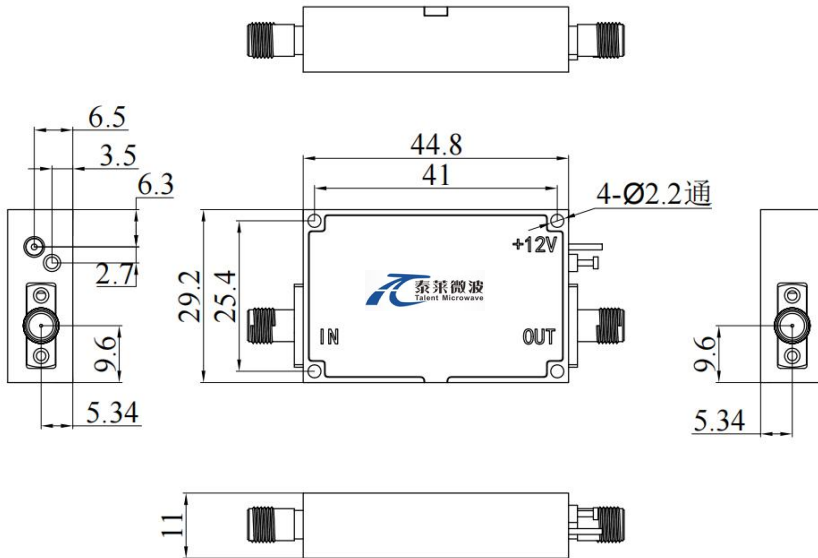

*****Heat Sink Required During Operation**



OBSERVE PRECAUTIONS
ELECTROSTATIC SENSITIVE
DEVICES

Environmental Conditions:

Parameter	Min	Typ	Max	Units
Operating Temperature	-40		+85	°C
Non-operating Temperature	-55		+125	°C
Relative humidity		95		%
Altitude	50,000			feet
Shock / Vibration(MIL-STD-810F)	25g rms (15 degree 2KHz) endurance, 1 hour per axis			
Shock(non operating)	20G for 11msc half sin wave,3 axis both directions			

Ordering Information:

Part Number	Description	Revision
TLLA50K20G-35-30	Low Noise Amplifier, 50K-20GHz, Noise Figure:3.0dB, Gain:35 dB,P1dB:15dBm,+12V DC,Without Heatsink	Rev.1.1
TLLA50K20G-35-30-HS	Low Noise Amplifier, 50K-20GHz, Noise Figure:3.0dB, Gain:35 dB,P1dB:15dBm,+12V DC,With Heatsink	Rev.1.1

Typical Performance Data:

Gain&VSWR vs Frequency

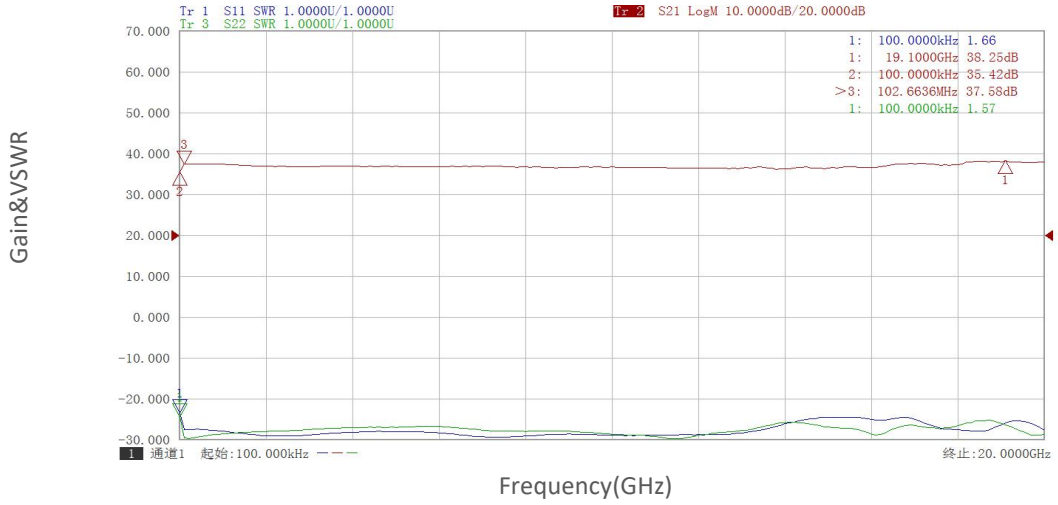

Noise Figure vs Frequency

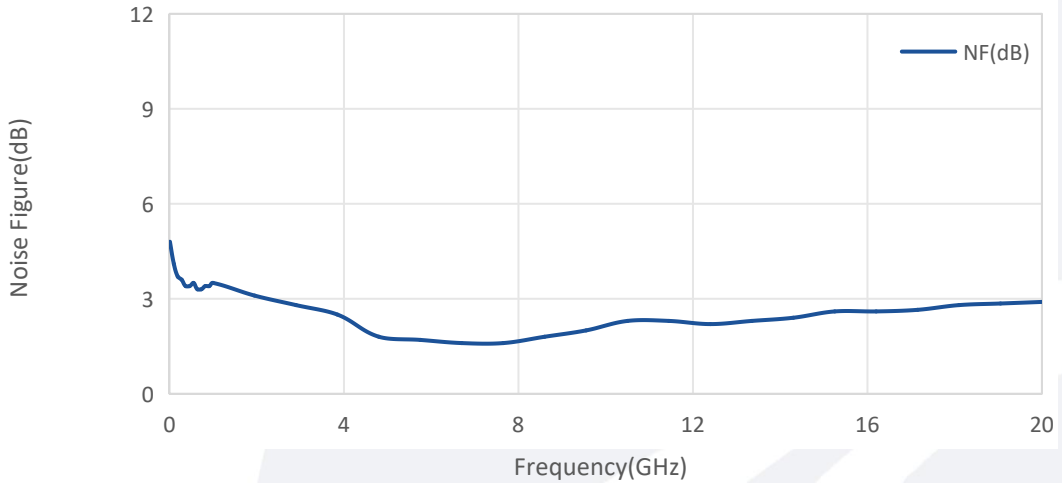

Gain vs Output Power

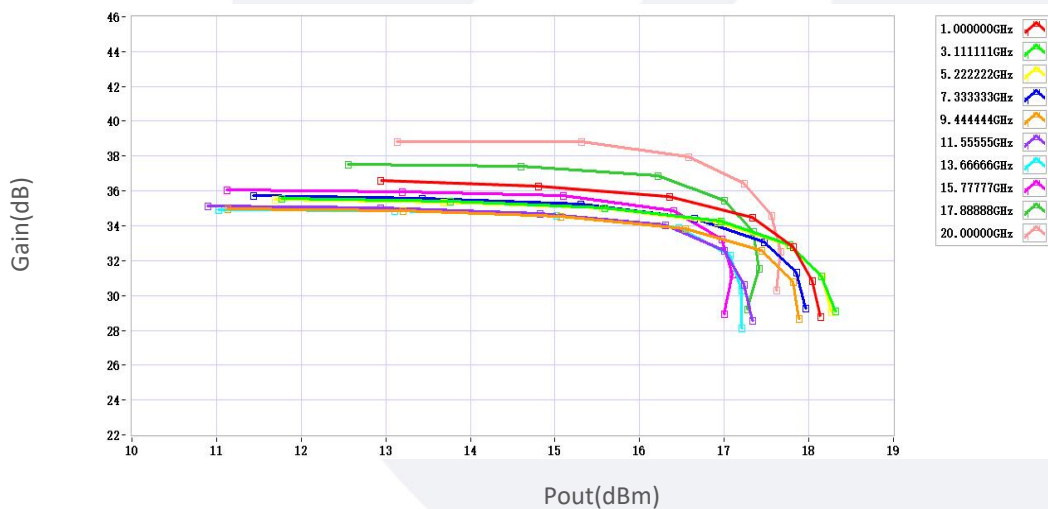

Typical Performance Data:

P1dB vs Frequency



P3dB vs Frequency

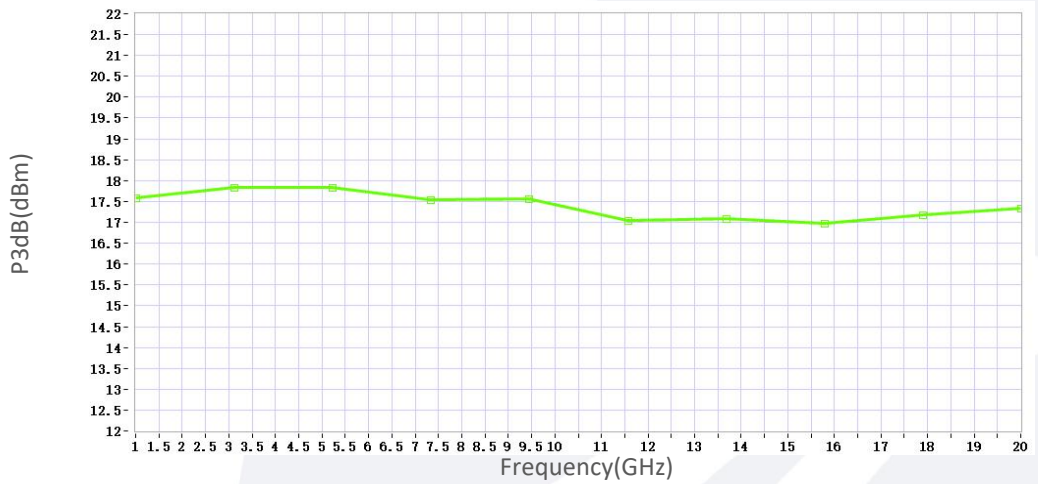

Psat vs Frequency

