

Model: TLLA1G18G-35-25
Low Noise Amplifier
1-18GHz, NF:2.5dB, Gain:35dB, P1dB:15dBm
Feature:

- Ultra Wide Band: 1-18GHz
- Gain: 35dB Min
- Noise Figure: 2.5dB Typ
- Good Power and Gain Flatness
- 50 Ohm Matched Input / Output

Electrical Specifications:

Parameter	Min	Typ	Max	Units
Frequency range	1-18			GHz
Gain	35			dB
Gain Flatness		±2.0		dB
Noise Figure		2.5	3.0	dB
Output P1dB	15	19		dBm
Output IP3		25		dBm
Input VSWR		2.0	2.2	:1
Output VSWR		2.0	2.2	:1
DC Voltage	+8	+12	+15	V DC
DC Supply Current		160		mA
Impedance	50			Ohms

Mechanical Specifications:

Parameter	Value	Units
Input /Output Connector	SMA Female/SMA Female	
DC Bias	Solder Pin	
Size	44.8*29.2*11	mm
Weight	55	g

Absolute Maximum Ratings:

Parameter	Value
Supply Bias Voltage	+15V
RF Input Power	10 dBm
ESD sensitivity (HBm)	Class 0, passed 150V

**Available 220V System
Benchtop Amplifier**

Outline Drawing:

Unit: mm(inches)

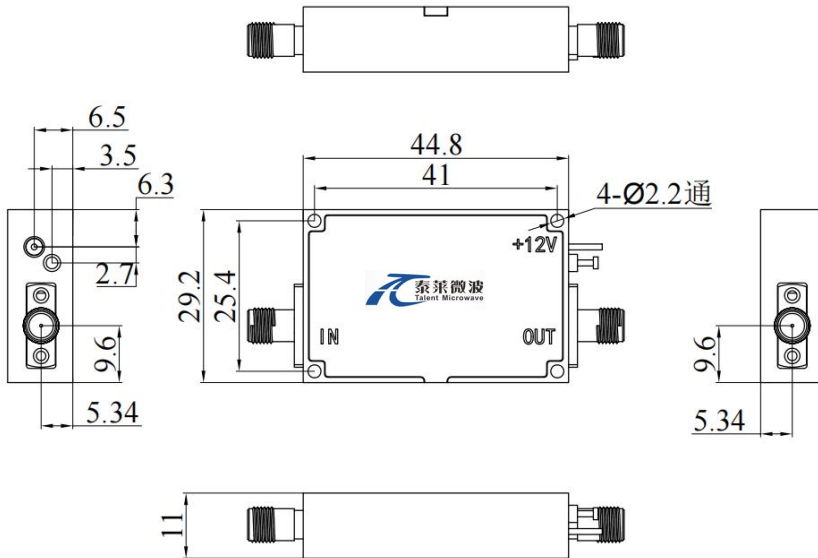

*****Heat Sink Required During Operation**



OBSERVE PRECAUTIONS
ELECTROSTATIC SENSITIVE
DEVICES

Environmental Conditions:

Parameter	Min	Typ	Max	Units
Operating Temperature	-44		+85	°C
Non-operating Temperature	-55		+125	°C
Relative humidity		95		%
Altitude	50,000			feet
Shock / Vibration(MIL-STD-810F)	25g rms (15 degree 2KHz) endurance, 1 hour per axis			
Shock(non operating)	20G for 11msc half sin wave,3 axis both directions			

Ordering Information:

Part Number	Description	Revision
TLLA1G18G-35-25	Low Noise Amplifier, 1-18GHz, Noise Figure:2.5dB, Gain:35 dB,P1dB:15dBm,5V DC,Without Heatsink	Rev.1.1
TLLA1G18G-35-25-HS	Low Noise Amplifier, 1-18GHz, Noise Figure:2.5dB, Gain:35 dB,P1dB:15dBm,5V DC,With Heatsink	Rev.1.1

Typical Performance Data:

Gain&VSWR vs Frequency

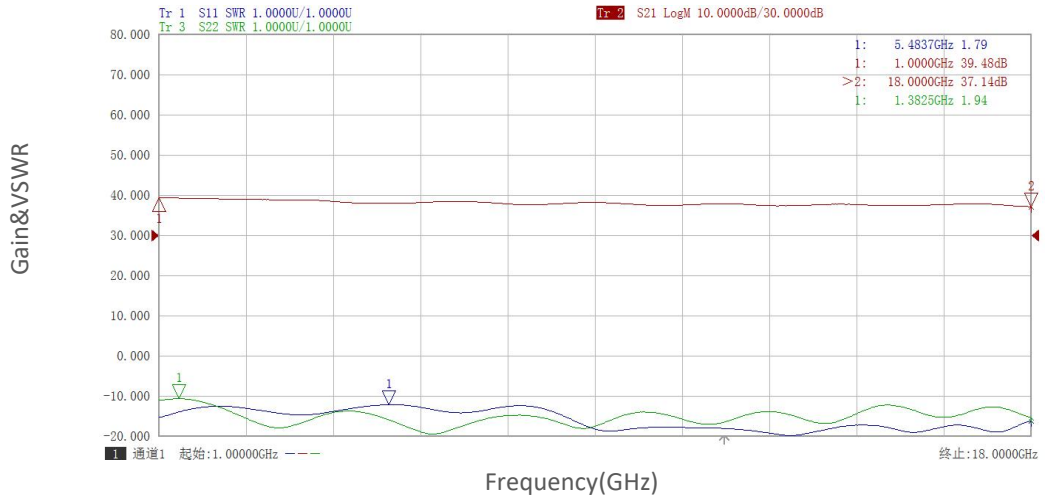

Noise Figure vs Frequency

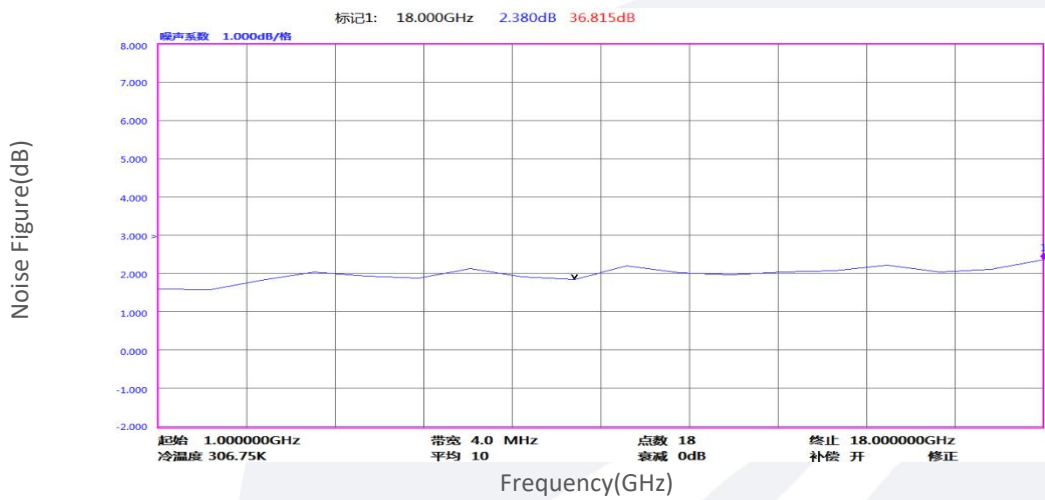

Gain vs Output Power

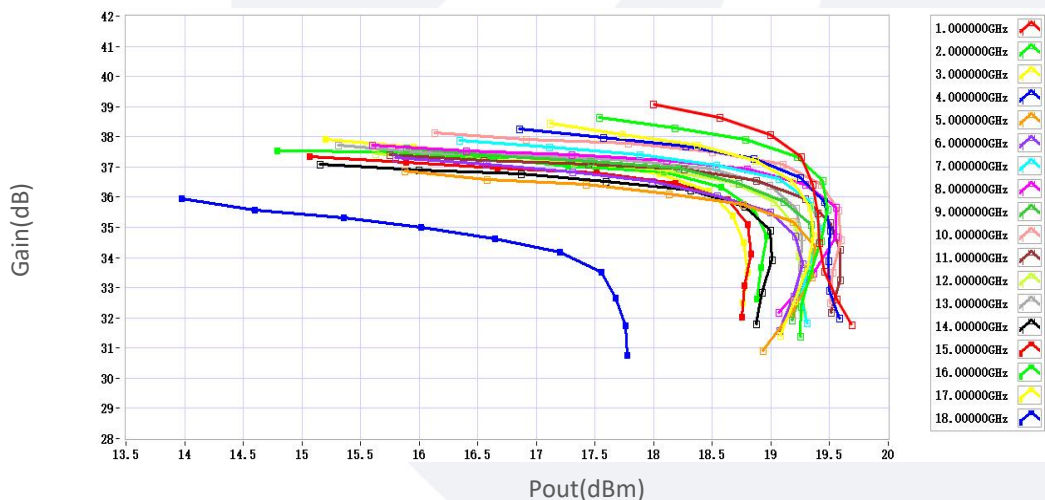

Typical Performance Data:

P1dB vs Frequency

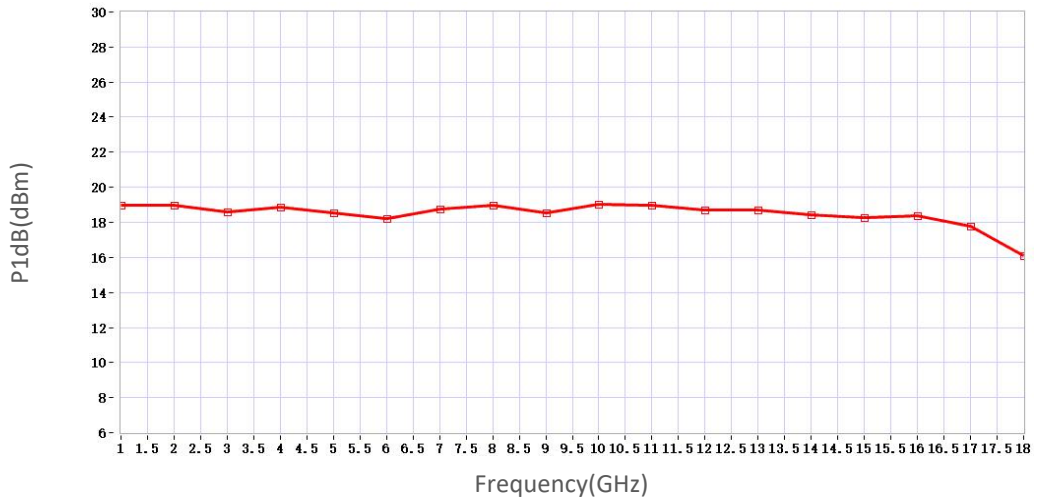

P3dB vs Frequency

